

In Vivo Raman Spectroscopy of Cancerous Skin Cells

L.A.S.E.R.S. - Live-Action Safe Examination Raman Spectrometer



Group 8 CREOL

Stephen Esposito	Computer Engineering
Michael Gonzalez	Electrical Engineering
Chelsea Greene	Electrical Engineering
Megan Melvin	Photonic Sciences and Engineering

Senior Design 1

60 Page Document - March 31, 2017

College of Optics and Photonics, Department of Electrical Engineering and
Computer Science

University of Central Florida

Dr. David Hagan, Dr. Lei Wei

Advising from Dr. Kyu Young Han

& Dr. Peter J. Delfyett

Table of Contents

Table of Contents

0	Mission Statement	1
1	Executive Summary	1
2	Project Description	2
3	Project Requirements and Specifications	3
	3.1 System Power and Data Flow Diagram View	3
	3.2 House of Quality	4
	3.3 Block Diagram	6
	3.3.1 Block Diagram Status	7
4	Research	7
	4.1 Skin Cancer and Diagnosis	7
	4.2 Raman Theory	8
	4.3 Raman in Biomedicine	9
	4.4 Raman Spectroscopy in Skin Cancer Detection & Diagnosis	9
	4.5 Specificity, Selectivity, and Sensitivity Scope of Studies	10
	4.6 Receiver Operating Characteristics	11
	4.7 ROC Curve Statistical Analysis	11
	4.8 Electronics Design	12
	4.9 Sensor Selection for Spectroscopy	12
	4.10 Printed Circuit Board	14
	4.10.1 General Layouts of Printed Circuit Boards	14
	4.10.2 Overview of PCB Components	15
	4.10.3 Assembling the Printed Circuit Board	16
	4.11 Microcontroller Research	17
	4.11.1 Microcontroller vs Stand-Alone System	17
	4.11.2 Microcontroller Choices	18
	4.11.2 Coding Research	19
5.0	Project Specifications and Related Standards	22
	5.1 ANSI Z136.1-2014 - Safe Use of Lasers	22
	5.2 Laser Hazard Classes	22
	5.3 ANSI Z136.3 - Safe Use of Lasers in Health Care	23
	5.4 ANSI Z136.8 - Safe Use of Lasers in Research, Development, or Testing	23
	5.5 ISO/TC 172 - Optics and Photonics	23
	5.6 IEEE STD 1-2000 - Temperature Rating and Insulation	23
	5.7 IEEE STD 1241-2010	25

5.8	Coding Best Practices	26
5.8.1	File Organization	26
5.8.2	Declarations	26
5.8.3	Statements	26
5.9	Power Standards	27
6.0	Project Constraints	27
6.1	Design Constraints	27
6.2	Time Constraints	27
6.3	Health Constraints	28
6.4	Economic and Cost Constraints	29
6.5	Size Constraints	29
6.6	Temperature Constraints	29
6.6.1	Heatsink Design	30
6.6.2	Material Selection	31
6.6.3	Active Cooling Design	32
6.7	Sensor Constraints	33
6.8	User Interface Constraints	33
6.9	Optics Key Design Constraints	34
6.10	Health and Safety Constraints	36
6.11	Overall Functionality Constraints	36
6.12	Printed Circuit Board Constraints	37
7.0	Project Hardware and Software Design	38
7.1	Printed Circuit Board	38
7.2	Probe Design	39
7.3	Spectrometer Design	39
7.3.1	Laser Excitation Source	40
7.3.2	Optical Fibers	40
7.3.3	Diffraction Gratings	41
7.3.4	Wavelength Filters	41
7.3.5	Lenses and Mirrors	42
7.3.6	Optics Handling	42
7.4	Casing Design	42
7.4.1	Casing Material	43
7.5	Sensor Apparatus	45
7.6	Power Flow Design	48
7.7	Programming Design	50
7.7.1	Cancer Sensing Algorithm	50
7.7.2	Graphical User Interface	50
7.7.3	Data Flow Design: TCD1304AP	52
7.7.4	Data Exporting/Storage Design	53

7.8	Thermal Flow Design	53
	7.8.1 Device Main Body	54
8.0	Prototype Construction	55
9.0	Project Testing Plan	55
	9.1 Project Technical Testing	55
	9.1.1 Optics Testing	55
	9.2 Laser Safety Testing	56
	9.2.1 Analog Replacements for Skin	56
	9.3 Optical Properties of Skin	57
	9.4 Note on the Sample Acquisition	58
	9.5 Sensor Testing	58
	9.6 PCB Testing	58
10.0	Administrative Content	58
	10.1 Estimated Project Budget and Financing	59
	10.2 Initial Project Milestones	60
	10.3 Preliminary Demonstration Plans	60
11	Project Summary and Conclusions	61
12	References	62
13	Appendices	65

0 Mission Statement

It is estimated that 87,110 new cases of invasive melanoma will be diagnosed in the U.S. in 2017, and melanoma only accounts for 1% of skin cancers (American Cancer Society). These patients have to visit a dermatologist to have freckles, moles, or other abnormal patches of skin checked for the potential of being cancerous. This usually results in a biopsy of the skin to be sent to a pathologist who uses a microscope to check if the skin sample is cancerous or noncancerous -- a process that may take several days to receive results. A biopsy is performed by cutting out or excising an area of the skin under consideration. This can be painful for the patient and may result in scarring. The stress of waiting for results is difficult for a patient waiting to hear potentially life-altering news. Further biopsies may need to be performed if the biopsy sample did not contain the abnormal cells, if the concentration of the cells was not high enough for an accurate diagnosis, or if the skin appears to change after the biopsy. Therefore the motivation of the L.A.S.E.R.S. project is to provide a non-invasive alternative to a biopsy for skin cancer screening, all while maintaining the same standard of accuracy and reliability and reducing medical expenses.

1 Executive Summary

In today's ever-evolving medical field, analysis and innovations go hand in hand. Without powerful technological advancements, it would be next to impossible to analyze cells, DNA, or gather information that could be helpful in the future. Medical breakthroughs cannot be possible with just theoretical data; tools need to be created to either prove or dismiss these theories. With L.A.S.E.R.S., such invasive techniques such as the standard biopsy will be rendered impractical and obsolete.

Our project's focus is to gather analytical data from skin samples, just as a general biopsy would, with the exception of having to actually remove the skin from the person. The way this is done will be through the use of spectroscopy: utilizing safe measures via a laser that will collect data through a charged coupling device, which allow us to view data points that can be plotted utilizing a microcontroller. From there, the data can be sent out via a screen or display to further analyze the results.

The components are configured in a modular format, which allows us to prevent issues such as overheating or diagnostic frustration. Having the components in their own separate spaces gives us the ability to detect errors in hardware and allow for quicker replacements, as well as have them preconfigured to work as stand-alone components. Modularity, however, will not render the project too large. This will be a portable, handheld device that can be utilized at the comfort of your home or office, so long as there is power.

Considering that the aim of this project is to make abnormal skin detection more affordable, this device will best be suited for individuals who are generally concerned with an abnormality on their skin, or a mole that they've always been curious about that they would like to analyze a bit further. The device will allow, under safe conditions, to detect any cancerous skin cells within the scanned area without the need of invasive procedures, or even a visit to their local physician. Through rigorous planning, project construction, research and development, our group will be creating a device that can be reliable, cost-effective, immediate, and most importantly, safe.

2 Project Description

The overall goal for this project is to design and build a compact, accurate, portable Raman spectrometer that can be used to identify cancerous versus noncancerous skin cells *in vivo*. It entails designing a Raman spectrometer that operates at a wavelength range known to obtain the identifying features of the Raman spectra of cancerous versus normal cells. The Raman spectra is analyzed to help diagnose the possibility of skin cancer as an early detection measure. This system offers patients and medical offices a more efficient and cost effective option compared to expensive Raman spectrometers and traditional biopsies. Patients will be able to see day-of results, faster when compared to a biopsy that must be sent away and processed in a lab. The use of a Raman spectrometer is less invasive for patients, as a biopsy requires the removal of skin cells from the potentially impacted body part. At the center of the project, this a Raman spectrometer that can be utilized for the specific application of skin cancer detection.

Research has been conducted and is currently being conducted to show that Raman spectroscopy is a feasible method for the *in vivo* diagnosis of skin cancers including basal cell carcinoma and melanoma [1-6]. A measurement method of interest includes *in vivo* spectroscopy using a fiber optic probe [3]. Using a probe would meet our design goal of portability. In a clinical setting, the use of a probe may be a comfortable method for the patient.

Medical technology is always relevant in the industry with new solutions always needed and improved upon. This project implements the range of talents across the team together and as individuals. It will use a combination of our knowledge from education as well as experiences at internships and careers, tying together traditional and practical knowledge.

This compact option is less expensive than typical on-the-market Raman spectrometer systems. A less expensive option for a doctor's office to buy and operate reduces patient fees. On average, a portable Raman spectrometer can cost anywhere from \$2,500 to over \$50,000, a range that varies with the purpose and accuracy of the system. The average biopsy without insurance costs approximately \$200, which adds up for a high risk patient that may need to have many biopsies performed. Lower fees mean that a patient may be more likely to have potentially life-saving testing done with less of a financial burden. Providing a reliable, safe, affordable, and effective option compared to current methods will prove this design as a success.

3 Project Requirements and Specifications

For this project, there will be several necessary components that have to be added to allow for proper data flow and power flow. From a data perspective, there are few methods to get accurate readings from skin samples from a scanned spectra onto a viewable interface. To accurately collect data from the spectrometer, the use of a Charged-Coupled Device (CCD) is required to convert the light collected from the laser into quantifiable data to be vetted. To securely and safely convert that data from light information, the use of microcontrollers will be necessary to guide the data onto a more viewable perspective. Once the microcontrollers can access the data and determine what has been seen via the spectrometer, there will be coding in place to provide a digital interpretation of the data that will be displayed onto a screen. Through our algorithm, our project

will be able to gauge if the scanned cells show cancerous traits. These traits will allow us to be able to provide the user with our interpretation of the presence of cancerous cells, as well as the ability to show these results to their trusted medical professional.

3.1 System Power and Data Flow Diagram Overview

From a power perspective, the main goal is to provide power to each component in the most modular way possible. Modular electronics are beneficial because of their heat reduction, lack of interference (especially in medical devices), and for its ease of troubleshooting and identifying rogue or defective components. To provide a modular design, there will be at least two Printed Circuit Boards (PCB): one dedicated for the initial power input and the microcontrollers, and the other specifically for the CCD and spectrometer. Due to the sensitivity of the laser and CCD, they will have their own PCB setup to ensure they are calibrated. The purpose of the first board will be mainly to provide power to the rest of the device.

To summarize the overall flow of the project, it was imperative to construct a power and data diagram to indicate the corresponding functions and interconnections of the major system components. This representation allows for a concise and understandable overview of the project, and what is actually happening from a data and power perspective. Figure #1 depicts the overall flow of the power and data in the system:

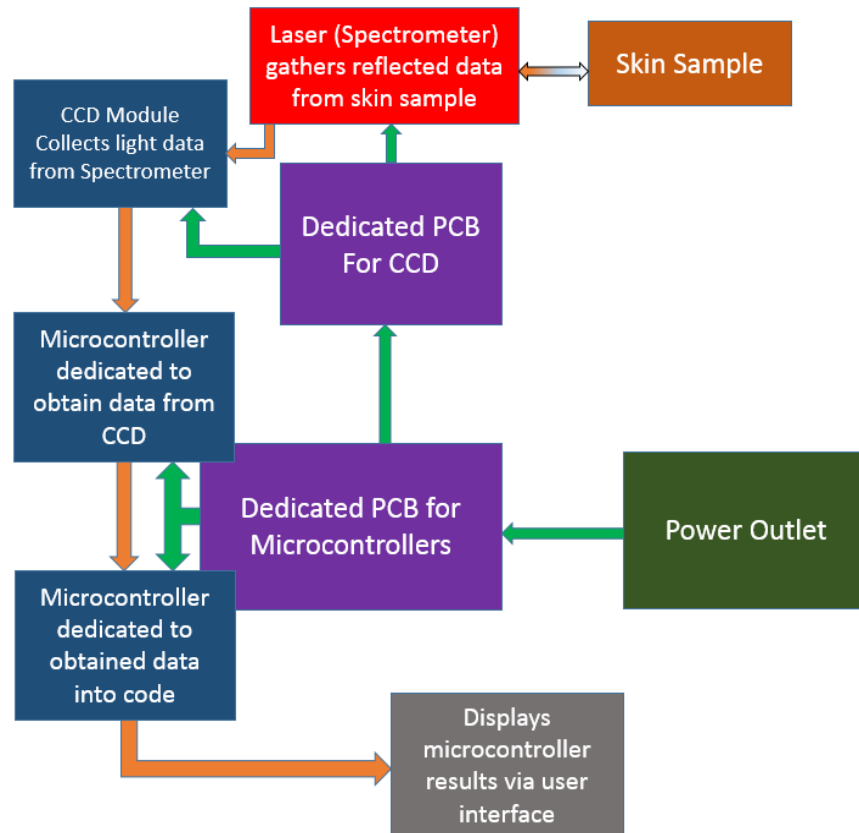

Figure 1: Data and Power Flow Design

For the power representation (green arrows), start from the power outlet and navigate to the first PCB (in purple). This PCB has three responsibilities: to obtain the power from the outlet, to utilize that power onto the two microcontrollers, and to distribute that power onto the second dedicated PCB. After the power is pushed onto the second PCB, the power is then divided between the CCD module and the spectrometer. This is the most cost-effective way to maintain a modular design.

For the data representation (orange arrows), it is best to begin from the initial data collection from the skin. The laser will propagate the excitation wavelength through an optical fiber connected to a Raman probe. Upon exiting the probe, the laser light will reflect off the sample and be re-collected by the probe. This reflected light will be filtered by the probe so that only the Rayleigh signal will propagate back through an optical fiber to the spectrometer. Within the spectrometer the Raman signal will be dispersed via a diffraction grating, and the signal will be collected by a CCD. Once that is done, the light data will be sent onto the microcontroller so that they can utilize that data as input for their code to represent whether or not the cells have cancerous properties. It will then send that result onto a user interface to verify and show their results.

3.2 House of Quality

As demonstrated in Figure 2, this project is intended to be cost effective, safe, reliable, and provide a shorter diagnostic response time. Accuracy does not impact reliability, however it will help decrease the response time while making the cost greater and the design less simple.

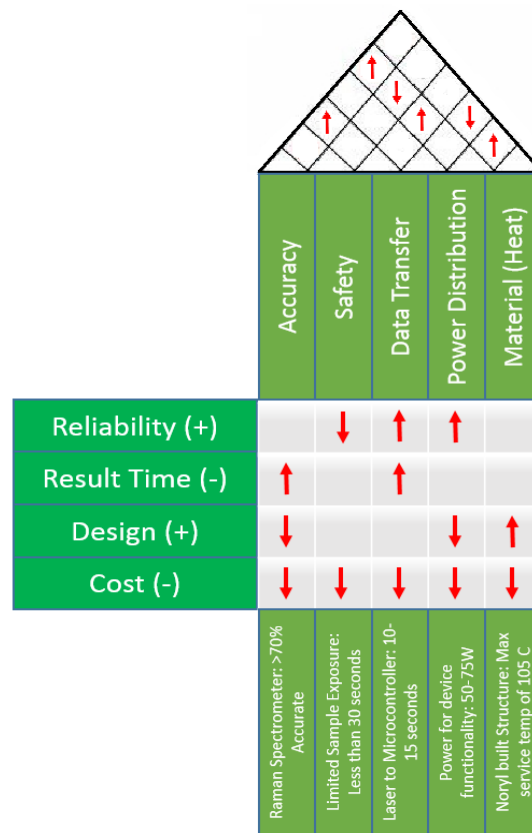

Figure 2: House of Quality

Safety will not impact the result time or the design complexity, but will increase the cost and make the system less reliable. Effective power transfer will increase the reliability and the cost of the system while decreasing the diagnostic response time. Efficient power distribution increases reliability and cost while improving the design. Choosing materials that can properly handle the heating of all electronic and optical parts will improve the design while increasing cost.

3.3 Block Diagram

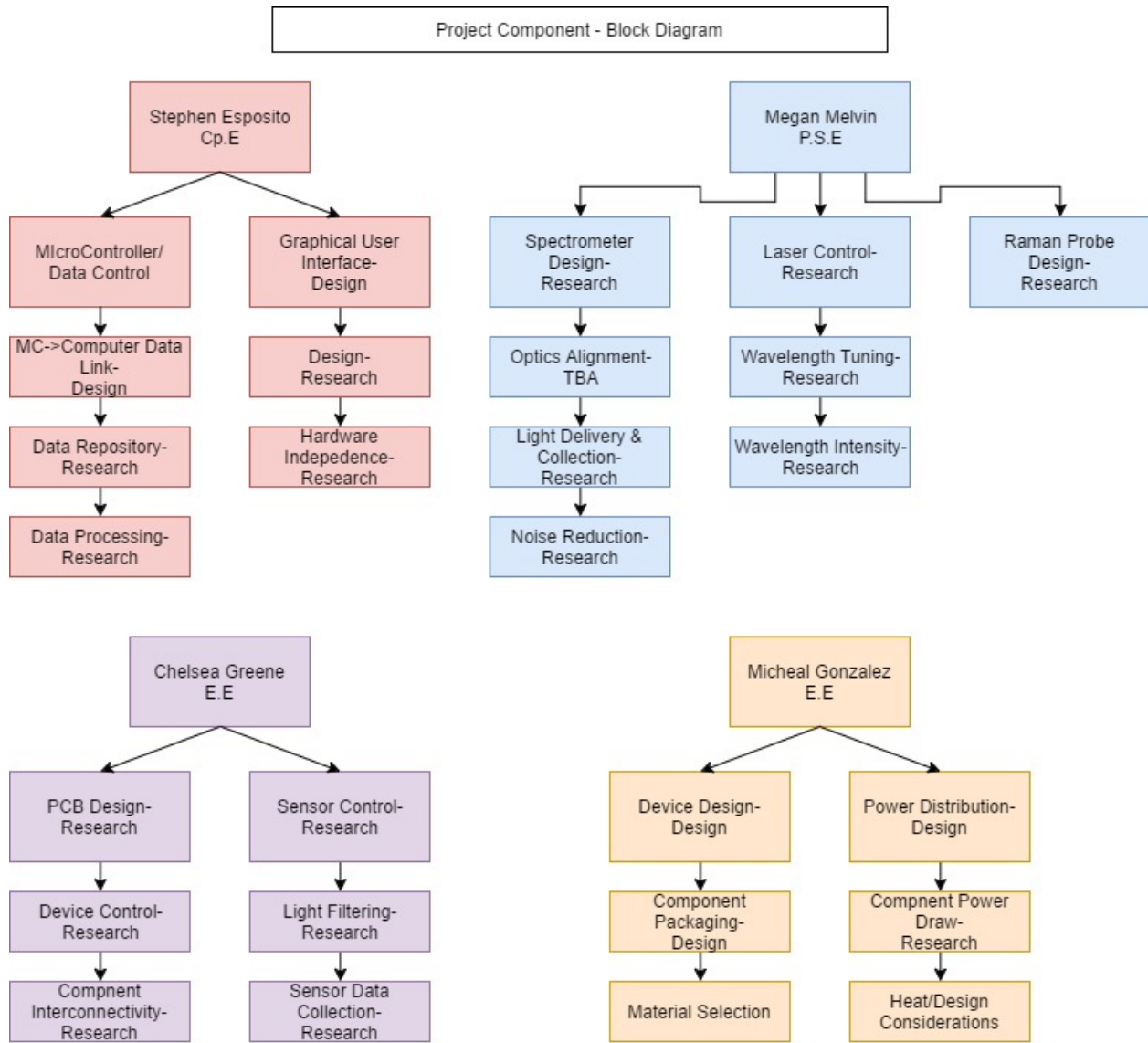

Figure 1-1

Figure 3: Block Diagram

Block Diagram Legend:

TBA: To Be Acquired

PCB: Printed Circuit Board for electronic components

Spectrometer: Optical instrument to measure light intensity as a function of wavelength; the Raman spectrum obtained will provide the Raman shift of the sample.

Microcontroller: Will be used to receive the optical data from the sensors and transfer the data to the main computer to be graphed and analyzed.

According to Figure 1-1, red blocks are the responsibility of Stephen Esposito; blue blocks are the responsibility of Megan Melvin; purple blocks are the responsibility of Chelsea Greene; and orange blocks are the responsibility of Michael Gonzalez.

3.3.1 Block Diagram Status

As of now, the majority of components are being designed, including the power consumption, heat distribution, device control, and the optics and sensors. The specifications of the spectra are being designed. The PCB, microcontroller, and parts for the spectrometer are to be acquired. The AutoCAD software, a potential laser, and microcontrollers are already acquired. Other items awaiting approval are prepared to be ordered and will not take long to be received.

The Electrical Engineers are responsible for the PCB, design, power distribution, and sensor control. The Computer Engineer is responsible for the microcontroller and graphical user interface. The Photonic Sciences Engineer is responsible for the spectrometer and probe design. Each team member will participate in the design of all four components.

4 Research

The research that has to be done to fully understand the concepts, components, and structure of this design is of the utmost importance. The research for this particular design is the first task that has to be completed, especially when all the hardware and software have to coexist at the most optimal level. It is imperative that every detail, from pin configurations, to PCB layout styles, to skin health, be explored and understood. The sections below will cover several categories that have been researched such as Raman spectroscopy, skin cancer and diagnosis, as well as the electrical and data representations.

4.1 Skin Cancer and Diagnosis

According to the Centers for Disease Control and Prevention (CDC), cancer is the second leading cause of death in the United States, and skin cancer is the most common form of cancer. Basal cell carcinoma (BCC), squamous cell carcinoma (SCC), and melanoma are three of the most well known skin cancers. According to the American Cancer Society, the most common type of skin cancer is BCC, while melanoma is the most likely cancer to metastasize.

It is paramount for the patient that skin cancer is diagnosed correctly and treated appropriately. When a dermatologist has suspicions of a lesion, a biopsy of the lesion is performed. A biopsy is the removal and examination of living tissue to ascertain the presence and extent of a disease. [Hendi]

Biopsies are achieved through several techniques. A shave biopsy is performed using a scalpel or blade to cut with a sweeping motion into the superficial epidermis while taking care to include

some dermis to detect any invasive disease such as melanoma. Care must be taken that the biopsy is not so superficial that a diagnosis could not be achieved or else a second biopsy must be done. A punch biopsy utilizes an instrument called a trephine, which is a cookie-cutter like tool to cut into the skin down to a desired depth. The skin sample must then be removed with forceps and cut free using scissors. An excisional biopsy removes the entire lesion, while an incisional biopsy removes a portion of a lesion that is too large to be completely removed. Sutures and/or bandages are often necessary at the removal site. Patients may have cosmetic concerns as temporary or permanent scarring may result from the biopsy. [Hendi]

A pathologist or dermatopathologist will examine a skin biopsy to determine the presence and extent of diseases. Skin samples are typically inspected with a microscope. Diagnoses depend on the interpretation of “tissue reaction patterns” and “patterns of inflammation” [Patterson]. Because biopsies are visually inspected and can present a numerous amount of various results, “[d]ermatopathology requires years of training and practice to attain an acceptable level of diagnostic skill” [Patterson]. Furthermore, obtaining the results of a biopsy may take one to several days, especially if there are delays due to sample processing and any special stains or additional tests that must be done for accurate diagnosis (American Cancer Society).

4.2 Raman Theory

The Raman scattering effect was discovered in 1928 by C.V. Raman. Raman reported that the energy of incident photons on a material was different from the energy of the scattered light. Raman recognized that this exchange of energy corresponded “to the partial exchange of energy into atomic vibrations of the molecules” [Lewis 12]. From this stemmed the development of Raman instrumentation and measurement techniques that have evolved to present day technology. [Lewis]

Molecules of different materials have different vibrational energy modes. When a molecule absorbs incident light of a certain energy h , the reflected or scattered light may be of equal energy h called Rayleigh scattering, lower energy $h-h$ called Stokes Raman scattering, or higher energy $h+h$ called Anti-Stokes Raman scattering. Figure 3 demonstrates these scattering concepts.

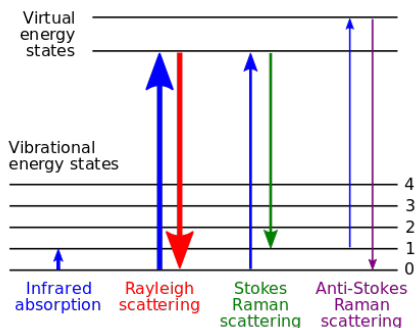

Figure 4: Representation of Rayleigh and Raman Scattering

Rayleigh scattering is a form of elastic scattering, meaning the incident and scattered light both have the same frequency. Stokes and Anti-Stokes Raman scattering are forms of inelastic

scattering, meaning the incident light is of a different frequency than the scattered light. The Raman shift is what L.A.S.E.R.S. aims to measure. Our spectrometer will ideally measure the Raman shift of a skin sample, analyze the spectral data, and determine if the skin sample exhibits a Raman spectra typical of normal skin or of cancerous skin, such as basal cell carcinoma.

The Raman spectra is the key data L.A.S.E.R.S. must acquire. The peaks in the spectra are characteristic of the sample being measured, resulting in a kind of “fingerprint” unique to the sample. Analyzing the wavelengths at which the peaks occur will provide insight into the molecular composition of the particular sample. Raman shift is typically measured in wavenumbers. To convert the wavelength (in nm) to wavenumbers (in cm^{-1}) requires the following equation: $w(\text{cm}^{-1}) = (1/\lambda(\text{nm}) - 1/\lambda_0(\text{nm})) \times 10^7$ where λ_0 is the excitation wavelength, λ is the Raman spectrum wavelength (nm), and w is the Raman shift in wavenumbers (cm^{-1}).

4.3 Raman in Biomedicine

Raman spectroscopy is popular in the biomedical field because the Raman signal interacts weakly with water. This is important because many biological samples, including human skin, consist mainly of water. Therefore the Raman signal will only strongly interact with other biomarkers of interest. Raman microscopy is popular for its diffraction-limited spatial resolution, making it ideal for imaging micron-sized biological cells. [McGarvey] For example, human skin cells are an average size of 30 microns.

The Raman scattered signal is weak, therefore, optimizing the signal through design considerations is necessary. Biological materials may exhibit fluorescence, the emanation of light resulting from the absorption of incident radiation. This fluorescence is often stronger than the Raman scattering signal, making proper signal analysis difficult. There are several solutions to overcome this issue including the use of ultraviolet (UV) or near infrared (NIR) laser excitation and signal processing methods, which will be discussed later. [McGarvey] UV and NIR wavelengths are outside of the typical absorption regions of biological materials that result in fluorescence. Additionally the water composition of the materials helps to reduce fluorescence. [Butler]

Lasers are an intense, monochromatic light source. Exploiting this intensity assists in increasing the Raman scattering signal and reducing acquisition time. On the other hand, this intensity may be damaging to the sample depending on the power of the laser and the excitation wavelength, particularly in the UV region. [Butler] Therefore L.A.S.E.R.S. will use relatively low power of less than 350 mW and a NIR excitation wavelength. A visible excitation wavelength will suffice if a NIR laser is inaccessible.

4.4 Raman Spectroscopy and Skin Cancer Detection and Diagnosis

Raman spectroscopy is appealing as a method of skin cancer detection and diagnosis. Current research [1-6] on the *in vivo* application of Raman spectroscopy promises a less invasive technique with fast results compared to a conventional skin biopsy. In one study by Gniadecka et al., the spectra of normal skin and BCC exhibited considerable differences when analyzing the spectral peaks of certain proteins and lipids present in the skin biopsy samples [1]. In another study by Schut et al., the Raman spectra was used to differentiate the border between normal skin and BCC,

demonstrating “the sensitivity of Raman spectroscopy to biochemical changes in tissue accompanying malignancy, resulting in a high accuracy when discriminating between basal cell carcinoma and noncancerous tissue” [2]. Silveira et al. concluded from their study that because normal and cancerous skin consist of different biochemicals, the intensities of the Raman spectra are different even if the concentrations of biochemicals are the same [3]. This indicates that the Raman spectra accurately represents the material under inspection.

The research conducted by Silveira et al. showed that the major spectral characteristics of skin originated from actin, collagens (I and III), elastin, and triolein. Research conducted by Gniadecka et al. showed that basal cell carcinoma and melanoma, in comparison to normal skin, exhibited changes in the intensity for the bands of proteins and lipids. For skin with BCC and melanoma, there was a decrease in the intensity for proteins in the regions of 1500-1800 cm^{-1} and 1310-1330 cm^{-1} . On the other hand, lipids exhibited an increase in the intensity around 1300 cm^{-1} . Our Raman spectrometer will observe these and similar bands to measure the Raman shift between normal and cancerous skin.

4.5 Specificity, Selectivity, and Sensitivity in the Scope of Studies

In various fields of study, analytics and statistics are indicators of how well or how productive a solution is to a problem. The three common analytical terms that are used to identify the best solution are selectivity, specificity, and sensitivity. To properly gauge how well the spectrometer can detect cancerous cells when scanned, the team needs to apply these three techniques.

Specificity refers to the quality of a choice or solution that is deemed the most effective or suitable for a diagnostic test. In the case of this project, our specificity is the measurement or proportional value of negative results that are correctly diagnosed with our spectrometer. With our device, the goal will be to properly gauge and identify the correct amount of negative results to eliminate false positives. To obtain an optimal specificity, the diagnostic should be able to properly eliminate most false positives, giving us a ratio close to 1:1.

Selectivity focuses on the extent to which a specified solution is selected to a distinct problem or condition. In pharmacology, for instance, selectivity is the extent in which a drug or dose of medicine will produce the intended effect for that illness. In many cases, specificity does not always guarantee selectivity, but specificity is a requirement to have a semblance of selectivity [12]. In regards to the device the team is creating to test for skin cancer, the selectivity of our project will be to accurately test for several forms of cancer while getting a low estimate of false positives and negatives.

Sensitivity is another analytical statistic that is important, especially in the field of science and engineering. Sensitivity is the the ratio in which samples or conditions are properly diagnosed under the correct criteria. In any given diagnostic test, sensitivity is also the probability that a given result is known as a true positive rate [13]. In general, if the sensitivity of a test is lowered, then the specificity of that same diagnostic test will increase. For our project, if the team tests for all types of skin cancer, our sensitivity will be higher, which decreases the specificity by nature. The main components that will provide the level of sensitivity will be the spectrometer, the CCD, and the microcontroller.

4.6 Receiver Operating Characteristics Curve

A great indicator for determining whether or not a diagnostic is accurate is the use of a Receiver Operating Characteristics (ROC) curve [14]. The ROC curve is well known to statistically determine the four different criterion for any given test: True negative, False negative, False positive, and True positive. Below is a graphical representation of an ROC curve with two different test populations:

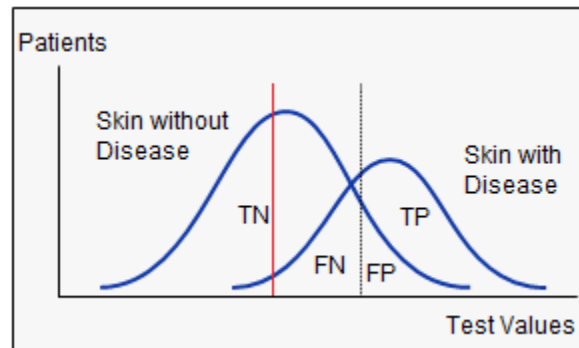

Figure 5: ROC Curve with the two Skin Types

Legend

TN: True Negative

FN: False Negative

TP: True Positive

FP: False Positive

The image above is a representation of two different skin types: One population with the disease, and the other population without. The dotted line at the center is the sensitivity line of the disease. Although the graphical representation has the sensitivity at approximately 50%, it is almost never the case in a real life diagnostic. Considering that the diagnostic test the device is examining for is all forms of cancer and carcinoma, the sensitivity will increase. This is represented by the red line on this image. The left shift allows for more positive results to be passed, which effectively eliminates the possibilities of having more false negatives. The result of the shift is to eliminate uncertainty from the user; at any point the test reads positive, the patient can then go to a professional to do further extensive examinations.

4.7 ROC Curve Statistical Analysis

The following equations are utilized in the ROC curve to determine what the ROC curve looks like, and how it can be directly related to the data :

Sensitivity = True Positive / (True Positive + False Negative); The true Positive rate of a disease being present.

Specificity = True Negative / (False Positive + True Negative); The probability that the test will yield a negative diagnosis when the disease is not present.

Other equations can be obtained from these two formulae, such as the ratio between the true positive and false positive occurrences (Sensitivity / (1 - Specificity)). Swapping the variables around, you also obtain the likelihood of a negative result ((1 - Sensitivity) / Specificity). The goal of these equations is to reconfigure our devices and spectra accordingly to obtain the most optimal results when diagnosing skin samples. All of the calibrations after the initial sample test from the first prototype will stem directly from the statistical analysis provided from the formulae above.

4.8 Electronics Design

The electrical engineers on the project understood what major components must be included in the spectrometer system design, however wanted to look into any research into the design process in order to be more effective and gain more insight into the system as a whole. The major components of the spectrometer include a sensor, microcontrollers, the optics system, a Printed Circuit Board (PCB) dedicated to power flow, a PCB dedicated to the sensor apparatus, and data connectivity. Thankfully, as with all technology, minimizing size is often a design goal. Research into ways to minimise the size of a Raman spectrometer will provide insight for the electrical requirements for L.A.S.E.R.S., which will be a relatively portable device.

A thorough investigation into size reduction is detailed in “The research of digital circuit system for high accuracy CCD of portable Raman spectrometer,” a useful resource to pin down what exactly is needed for a Raman spectrometer to be both smaller and effective, particularly with respect to the electronics design. Although the described designed uses a few pieces that vary from the design plans for L.A.S.E.R.S., the main component logic remains the same. In general, “The digital circuit system for high accuracy CCD is composed of multi-voltage circuit, sequential generation circuit, driving circuit, A/D transition circuit and data exchanging interface,” [15]. These elements allow the the sample to be read and the data sent to the tablet or computer that will tell the device user their results, which is the goal of the spectrometer design. Analog to digital conversion and any associated standards will be an important element to a successful spectrometer. The signal read in from the sensor, will go through programmable gain amplifier (PGA) and a analog to digital converter in order to be processed [15]. The cleaner the signal, the more noise can be reduced. A reduced signal to noise ratio is ideal for any system, but especially while seeking the Raman shift. The research article also notes that it is important to note the clock information for the specific sensor [15]. Understanding how the specific sensor functions is essential to designing a system that is precise, efficient, and will deliver the most accurate data.

4.9 Sensor Selection for Spectroscopy

A sensor is used to read in light and convert that information into data, which can then be read in and analyzed by a microcontroller. This piece is essential to bridge the data read in by the probe to the data that will be delivered on the user interface to the patient or doctor using the device. Such sensors are used in a variety of applications involving the processing of images or light data, from digital cameras, to astronomy applications such as telescopes, and medical imaging. Given their usefulness and versatility, it was clear that a sensor would be an important aspect of this project. In any application involving the processing of light or data from an optical apparatus will require a sensor device.

The sensor that collects the data from the probe apparatus could be either in the form of a CMOS (complementary metal-oxide semiconductor) or CCD (charge-coupled device), the two most popular and common types of sensors. Both systems take on the same task of converting the data in the form of a wavelength of light into electrical signals that can be read and processed by a signal processing system. It is important to understand the difference between CMOS and CCD sensors, as well as to understand which applications most commonly use one or the other. Compelling arguments for the use of both CMOS and CCD sensors exist; the application of the system is the most essential aspect in making the final decision of which type of sensor to utilize.

Initially, a CMOS sensor seemed more attractive. In general, CMOS are cost effective in a variety of formats and sizes. With optics parts running a typically high price point, trying to keep within budget on this part felt essential. In general applications involving medical technology, CMOS have proven successful. In a comparison of CMOS and CCD specifically for biological image applications, it was found that, "...even a mid-performance CMOS camera can extract close enough information to that of a CCD camera when applied to get information on the spatial distribution of the fluorescent signals on an image. Therefore, CMOS cameras may also be considered for quantitative investigations on cells or tissues when dealing with fluorescence microscopy," [16]. In this article, researchers compared the validity of a CMOS sensor to a comparable, and more preferred, CCD sensor. The article conveyed a sense that a CCD sensor would be the more ideal option, but with modifications the two could perform on similar levels. Thus, if the team needed to use a CMOS sensor should the price of a CCD become unreasonable for the constraints of the project, it would be possible to complete the task given the research on the topic.

Despite being typically more expensive, it was important not to ignore a CCD sensor on the basis of only a rough price estimate. If articles existed to discuss how to bridge the gap between CMOS and CCD sensors, there must be a reason why CCD sensors earned a reputation for success in the medical field. A particular focal point was placed on finding examples of CCD sensors in Raman spectrometer devices in order to justify which direction to take. In a journal article specifically discussing the biomedical applications of Raman spectroscopy, the use of a CCD sensor is discussed in detail, along with how a CCD sensor is utilized in this system. CCD sensors are effective at picking up the Raman spectrum, and an efficient handheld spectrometer can work with just a single dimension CCD array [17]. Learning that it is possible to have an effective device that does not have a larger, more expensive array was essential to moving forward in this project. The idea of using a CCD array was attractive based on the apparent preference for using one specifically for Raman spectroscopy. The idea that using a single array would decrease the cost compared to a more square-shaped CCD, commonly used in cameras, offered hope that a CCD array that met the economic constraints of L.A.S.E.R.S. could be procured.

While the price point of the CCD became worrisome, it was found that a CCD would be more ideal for a Raman spectrometer. Dr. Han informed the team that a one-dimensional CCD array would be ideal, but could cost up to \$300. In Dr. Han's professional opinion, a CCD sensor has a better quantum yield, essentially the absorption of the data from the sample, of approximately 90% compared to a CMOS sensor's approximately 50%. The quantum efficiency will vary based on the wavelength of interest, however this general observation was yet another encouragement for a

CCD array. In addition to their high quantum efficiencies, CCDs are also capable of low signal-to-noise ratios (SNRs). To reduce dark or thermal noise from the CCD, it is possible to cool the detector using liquid nitrogen or thermo-electric Peltier cooling. Additionally, the use of a deep-depletion CCD instead of a back-illuminated CCD will help to reduce noise and reflections of the near-infrared light to be used. [11] A reduced SNR also means a potentially less rigorous signal analysis while processing the received data from the probe. While meeting with Dr. Hagan during a review of the team's initial document, he also suggested a linear CCD array. With the professional opinion of faculty advisors behind the idea of a CCD array, this settled decision to select this type of sensor, so long as the team could find one that met project constraints. The next step, as noted in the project components section, would be to find a CCD array that fits the project budget and meets design specifications. Thankfully, the team was successful in finding a sensor that matched all of these goals using a single array CCD sensor.

4.10 Printed Circuit Board

A printed Circuit Board (PCB) is the main board that interconnects all of our electrical components via conductive features that are engraved from copper, and then is placed on an insulated substrate, usually plastic. In any electronic application, PCB's are the backbone component that interlaces all other components to communicate efficiently. Not only are PCB's important for supplying power to any application, but it is also useful in supporting mechanics. The fact that it has lasted decades in the electrical industry is telling, and its presence in the market is overwhelming; now existent in cellular devices, embedded systems, televisions and even automobiles [18]. This project will require at least two circuit boards for full functionality: one will be dedicated to the power and maintenance of the microcontrollers, and the other will be solely for the power and maintenance for the CCD and the spectrometer. Again, this was done as a precaution; the intent to divide the device's system for better serviceability from the CCD and the spectrometer. This will provide a more accurate result and will pose for easier calibration once initial data has been computed. If resources were to be a constraint, the next possible option would have been a multi-layered PCB that can handle both the microcontroller and CCD/Laser applications.

4.10.1 General Layouts of Printed Circuit Boards

Of all the different circuit board construction templates, the three most common are the single-sided PCB's, the double-sided PCB's and the multi-layered PCB's. For single-sided PCB's, they dedicate one side of the substrate for the components. A double-sided PCB is introduced when the amount of components exceeds either the physical or electrical capabilities that a single-sided PCB harbors. The way the two sides communicate with one another is by drilling into the substrate onto the other side and plating the holes with copper or any other conducting metal. The multi-layered configuration, however, will differ by having layers of insulation in between the layers of printed circuitry. The way the layers interconnect with one another is by having the components configured on the top layer connect onto the plated holes that are connected to the corresponding circuit layer [19].

In short, the simplicity and complexity of PCB configurations and schematics can be understood by observing the amount of layers that are on the PCB. For instance, a simpler PCB will have 1-2 layers versus a more complex design, which can boast 7-10 layers. The more layers added, the

more copper patterns and arrangements are added. This is significant because it will allow the copper to not overlap between their lines, which will evade the problem of having the electricity flow undermined [20]. Over the copper layer is the solder mask, where all the copper lines and traces roam to their components to power the system. The purpose of the solder mask is to protect the copper from contacting any other metals. Lastly, a silkscreen is also added over the solder mask to properly map the lines and components to allow for easier assembly and installation.

4.10.2 Overview of PCB Components

The PCB is capable of housing various components, all which have different functionalities and qualities intended for a particular circuit schematic. Most, if not, all of these common components have been utilized in labs such as Networks and Systems, Electronics I/II, and even Embedded Systems. Below is a list of the most common PCB Components:





PCB Component	Electronic Symbol	Description and Use
Battery		Supplies a voltage to the circuit design.
Resistors		Controls the current throughout the circuit.
Inductor		Stores energy in magnetic field; resists changes in current.
Capacitor		Accumulates electrical energy when attached to a voltage.
Diode		Maintains current flow in one direction only.
Transistor		Used as a current amplifier; also can act as a switch in ON or OFF states.

Table 1: PCB Components and their Uses

There are two main methods of connecting the components onto the circuit board: Through-Hole-Technology or via Surface Mount Technology (SMT). The former requires that small holes be drilled through the board itself to allow for thin leads from the component to pass through. Once the leads are passed, they are then soldered onto pads on the opposite face of the circuit. The latter method - which has been the industry standard since the 1980's - has proven to be a more feasible solution to adhering components onto the circuit boards [21]. Instead of having to drill small holes through the board and risk potential damage, or risk incorrect hole sizing, components could be soldered directly onto pads that sit on the surface of the circuit board. For the two PCB's that are being designed, the most time-efficient and cost-friendly method would be the standardized SMT.

4.10.3 Assembling the Printed Circuit Board

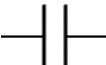
Now that there is a basic understanding of the PCB and its natural design structure, this next segment will introduce the assembling of the PCB itself. There are about 4-5 steps to have a completely functional PCB, starting from the design schematic, all the way to assembly and troubleshooting. For the vast majority of the project, the PCB will be in the possession of a professional designer, but the most crucial steps are taken at the very beginning, where the design has to be laid out and properly configured. Below are the procedures to creating a PCB:

Circuit Schematic Design: To begin the process, the first portion that has to be done is to create a working circuit design. In most cases, a way to test for a viable circuit is to generate the circuit layout onto a circuit simulator on a computer, as well as by testing out that same circuit via a breadboard. Once all the outputs are within a specified degree of freedom and the circuit is fully functional, the next step is implemented.

Board Design through Software: Once the circuit is working and designed, the next step is to have that circuit rendered into an Electronic Design Automation (EDA) software [22]. There are several EDA softwares to choose from, such as Eagle, Allegro, and KiCAD, but the constant within the software has to be the file format. The standard file formatting is the Gerber format. This format communicates with the software to outline the components onto the PCB and illustrates different dimensions of the PCB. Images can be created from the file, almost like a PDF format, to show where certain components are sitting, or where the copper wires will transport the current. When creating the PCB, be mindful that there are different configurations of boards. It is important to mention that the design has to be created in reverse on the software do to the viewpoint of the board [23]. If the project that is being implemented needs more components and more copper leads, then utilizing a single-sided layout will not be ideal. Once the software creates the Gerber files, the PCB can start the fabrication process.

Printing and Initial Fabrication of the PCB: The gerber file that is given to the fabricator will have several layers depicting drill hole locations, signal traces, and component layouts, making it easier to read and fabricate. The PCB will go through several stages in the fabrication before it can be ready to test. These stages include etching, drilling, component plating, and protective electrical measures. After the stages are complete in the fabrication, the board itself will be tested to ensure the fabrication and design was done correctly.

Testing the PCB: A PCB does not only have to pass certain electrical evaluations, it must also be tested from an aspect of rigor and durability. Verifying the functionality of the PCB is arguably the most extensive procedure in the assembling process. Depending on the application it is being used for, a single PCB can be subjected to many tests, rating certifications, or industry standard examinations. For all applications, however, the PCB must go through an electrical test that verifies all the points of contact throughout the board. This ensures that the design inputs and outputs can be verified, and can also guarantee the fabrication is working. Once the leads and contact points are tested and fully functional, the last step is to mount the components for final assembly.

Final Assembly of the PCB: After all the contact points are tested and cross-referenced in the design specification, the last stage of the PCB is to have the components mounted onto it. As stated in the earlier sections of PCB's, the type of mount is decided in the design section. If the design required the components to be installed using a through-hole mount, the leads are inserted into their respective holes and lead into their respective contact positions according to the design. However, if the design required the components to be installed on the surface of the PCB, then the components will be soldered onto pre-configured pads that match with that specific component. Once the components are secured onto the board, the components will also go through a form of electrical troubleshooting to ensure they are working properly. After the test concludes and all of the components are tested, the PCB can be declared viable and complete for use.

4.11 Microcontroller Research

The device may use at least one microcontroller in order to process the signal read in by the sensor apparatus. Not only must the potential microcontroller(s) be considered, but also their arrangement and usefulness to the spectrometer. A stand-alone computer system could also be used in lieu of additional hardware. The research into these important decisions is described in detail in this section.

4.11.1 Microcontroller vs Stand-Alone System

Both a microcontroller and a stand-alone computer system have similarities that can blur the decision whether our application would require each system. Both systems have a processor, RAM, and the necessary input and output devices the team needs in order to be able to control the CCD array, and capture the relevant results from our tests. Each system has its positives and negatives for incorporation into the device itself.

Microcontroller:

- Small
- Power Efficient
- Easily Interfaceable with CCD
- Can only perform a single task
- Requires an outside computer system to then further interpret the data.

Stand Alone System:

- Too large to fit "inside" the handheld device
- Huge power draw
- Harder to interface with CCD
- Can perform all necessary tasks of both Microcontroller and Stand Alone system

In the end, our decision on whether to have a microcontroller independent of our external computer system became quite clear. To gain hardware independence, we would incorporate a microcontroller inside the device, so we can use an external program that can run on any machine to then review the results.

4.11.2 Microcontroller Choices

Arduino Uno

The Arduino Uno is a board based on the ATmega328P. It is a great beginner microcontroller board that has 14 Digital input/output pins, 6 analog inputs, a 16Mhz quartz crystal, a USB connection, and a low power draw. This board is designed for beginners to programming to do very simple at home projects, many of which include photography and other photo sensor data. This is a very lower power system, and would handle just the aspect of relaying the sensor information to our computer system without fault, but the low power of the system could also be a bottleneck if more data throughput is eventually necessary. The cost of this microcontroller device is a non-prohibitive \$20, which lends itself to creating a cheaper final product. However, with the desired real time results, the minor savings of the overall system is not worth the delay this device may cause us over some of our other options.

Quick Computation Specifications:

Processor Speed: 16Mhz Quartz Crystal

Flash Memory: 32KB

SRAM: 2KB

Quick Design Specifications:

Input Voltage: 7-12V

Length: 68.6mm

Width: 53.4mm

Weight: 25g

Texas Instruments MSP4305172

The Texas Instruments MSP4305172 is a 16-bit ultra-low microcontroller platform which is used for a wide range of low power applications. It is a great learning development device that has 29 GPIO pins, a 25Mhz Crystal, a USB connection, and a super lower power draw. The board is designed for learning and use in several types of Analog and Digital Sensor systems. Much like the Arduino Uno, this device would only be able to handle the aspect of collecting the sensor information and passing it off for collection/retention to our computer system. The system provides ton of customizability and has applications in many fields, but the ability to handle the data stream, and then further process it would be too much for this lower powered system. The low cost of ~5 does provide a greater degree of freedom with budget, however we would have to create a housing, as well as as design a development board to provide the necessary IO ports which provides additional cost and design time.

Quick Computation Specifications:

Processor Speed: 25Mhz Crystal

Flash Size: 32KB Flash

SRAM: 2KB

Quick Design Specifications:

Input Voltage: 1.8-3.6V

Length: Depends on Custom PCB Size
Width: Depends on Custom PCB Size
Weight: Depends on Custom PCB Size

Raspberry Pi 3

The Raspberry Pi 3 is a 64-bit low-powered computer platform which is used for a huge range of applications ranging from imaging devices to a full mini-computer environment. Unlike the microcontrollers described before this, this system is capable of running a full version of Linux, and is a much more robust system, which can be capable of both relaying and storing the data gathered by the spectrometer system. Its 1.2GHz ARMv8 CPU, 1GB RAM, expandable HD space via MicroSD and 40 GPIO pins allow for this system to handle a larger chunk of the responsibility, along with a greater sense of independence from a full computer system external to the system. This device comes housed and has the necessary PCB to be able to control any sensors we may need for our design, as well as the intended functionality of capturing our sensor data simultaneously.

Quick Computation Specifications:

Processor Speed: 1.2GHz 64-bit Quad Core Armv8 CPU
Flash Size: 1GB RAM
Storage: 32GB (via MicroSD)

Quick Design Specifications:

Input Voltage: 5V
Length: 4.8”
Width: 3”
Weight: .6 Oz

4.12 Coding Research

The back-end code for this project will provide the necessary flow of data from the sensor arrays into a form that the users can understand, and thus makes will make our product a viable option to bring to market. Different aspects of the code will have different responsibilities, but the end goal is consistent, providing an easy to use, reliable system to deliver accurate test results.

Without bogging down too much in the design aspect of our code, which will be covered later, we are aiming to provide a relatively high-level program which should prove to be cross platform, without the need for lower-level system processes. This has led us to several choices we may choose to program our project in, with initial compatibility being designed for use on a modern Windows Computer and a Raspberry Pi 3 microcontroller.

Python

Python is a high-level programming language used mainly for general purpose programming. It was created by Guido van Rossum, and first released in 1991, and emphasizes readability and a syntax that programmers find easier to express concepts in less lines than in other programming languages. Python is a multi-platform system, and is readily available on most current operating systems. Unfortunately, Python requires a native compiler that can take the code and transform it

into something the host system can handle. This simultaneously restricts the overall number of system that it can run on, but allows the overall speed of the program running to increase.

Some of the features of Python that may prove beneficial for our use case are the dynamic coding approach, as well as Python's program speed. Since of our largest design features is real-time results and accuracy, a program that runs as fast to real-time as possible is ideal. However, we need to also take into consideration the ability of running this on several systems, as one of our other intentions is for this to be an at-home device.

Java

Java is another high-level programming language originally created by Sun Microsystems in 1995, developed for general purpose computing. Java is a concurrent, class based, and object oriented language, which natively has fewer dependencies on hardware. Programs written in Java are compiled for use in the JRE (Java Runtime Environment), which are then able to be run on any hardware capable of running the JRE, regardless of computational power, operating system, or hardware.

Due to the modularity constraint of our project, Java's native platform independence is an indispensable tool, that will allow us to take the working code and run it on any of the 3 billion devices currently running Java. That portability factor allows the implementation of our microcontroller to change as we are able to come up with final design constraints.

Java is also known for having a large database of classes that are written, to prevent users from having to re-write the same functionality. This feature set will allow us to make changes and modifications to our source code to troubleshoot more effectively.

Data Analysis

The microcontroller will be receiving data from the CCD in two value formats. One value will be the wavelength we are testing at (measured in wavenumbers cm^{-1}), the other value will be the intensity of light (measured in A.U (arbitrary units)), which is a measure of the number of photons received by the CCD array. The combination of these values will be further translated into a dataset which our program can then work with to determine the likelihood that our patient is at risk for cancer.

For standard spectroscopy, the cancer indications would be in how the data changes from a non-cancerous skin sample versus a cancerous skin sample. The deviation in these data sets will further indicate an unstandard cellular makeup, which may include the possibility of cancer cells. The dataset will be plotted in an (X,Y) format using (Wavelength Numbers, Arbitrary Unit).

We will be analyzing the data for any large variations of two parameters: Intensity (change in Y-axis) and Raman Shift (change in X-axis). Though our methodology for a definitive decision is not yet decided, we will be using two well known algorithms to determine each one of these shifts.

Intensity Shift

Intensity shifts will be experienced when there is a large variation at a single peak, This change in peak can be attributed to the presence of a non-standard cellular makeup. To test for this, we will

be comparing individual data points for changes in intensity larger than a defined value, larger than a later defined standard deviation of normal skin comparisons.

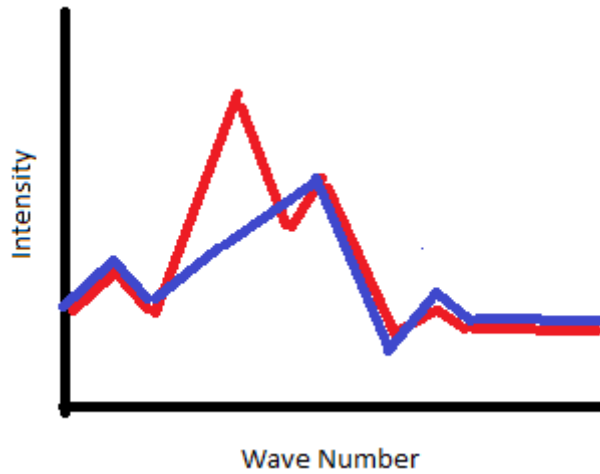

Figure 6: Intensity Shift Example

Intensity shift will also be measured looking at the Euclidian distance of the lines comparing the data values, and testing for the average change. Two standard tests on a similar piece of skin should result in a net Euclidian distance change of ~0, so this will be indicative of a large shift in intensity using the following formula. [24]

$$\left(\sum_0^n (y_{n2} - y_{n1}) \right) / n$$

Phase Shift

Phase shifts will be experienced when there is a large variation in the Wave number location of our large peaks. This also can possibly indicate the presence of a non-standard cellular makeup. Testing for this will be more complex and will require the program to test for a shift in both directions, accounting for the possibility of the number of peaks changing due to this shift.

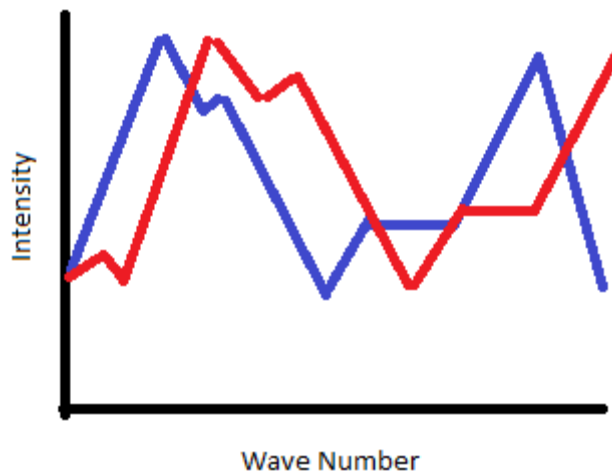

Figure 7: Phase Shift Example

5 Project Specifications and Related Standards

In order to design a safe, effective, and marketable device, the L.A.S.E.R.S. system should adhere to some key industry standards. Adhering to standards is beneficial not only for the design process, but also when marketing and explaining the device to other engineers or professionals. Some standards focus on safety, which is of utmost importance. Such standards should be considered a priority. Other standards discuss basic implementation of a type of system or device, which is useful for the design process. Another standard type that comes in handy while building a device and selecting parts is related to procedures for testing a certain kind of system. There is a variety of standard types, useful guides that can be utilized in all steps of the design and construction process.

Given the nature of this project, the focus was placed on standards related to power distribution, laser safety, and other processes related to the flow of data within the device. Working with a laser was a new experience for most of the team. A full understanding of what dangers the team could face as well as what to look out for while designing for safety was an essential point of research. Other standards are useful and helpful tools, especially for beginner designers, however understanding safety is always the top concern.

5.1 ANSI Z136.1-2014 - Safe Use of Lasers

ANSI Z136.1-2014 is the American National Standards Institute's most current edition of the standard describing the Safe Use of Lasers. Z136 is a series of laser safety standards, while Z136.1 outlines the measures for safely operating lasers, classifying lasers according to their potential hazards, and controlling these hazards. The laser hazard classes are described in the following section. Technical information including calculations in determining hazard classes and the appropriate optical density of eyewear is included in Z136.1.

5.2 Laser Hazard Classes

Lasers can present unique safety hazards. Lasers are highly focused, highly directional beams of intense light. Improper handling of lasers can result in serious eye damage and burns to the skin. As such there are strict standards and regulations that must be followed in the manufacture and use of lasers. The Food and Drug Administration (FDA) identifies four major classifications of laser hazards. Other organizations with similar laser hazard classifications include the American National Standards Institute (ANSI) and International Electrotechnical Commission (IEC). The laser hazard classes are described in the following paragraph.

As defined by the FDA, there are four major laser hazard classes (I-IV) with subclasses (IIa, IIIa, IIIb) describing the dangers posed by such lasers. An increase in the class rating means the lasers are more powerful and pose a greater risk. Class I lasers are non-hazardous, meaning the laser cannot emit radiation at levels that can damage skin and eyes. This hazard increases if optical aids such as magnifiers are used for viewing. Class II and IIa lasers are visible lasers that cannot cause skin or eye damage if viewed for a time period less than the human aversion response of 0.25 seconds (II) or maximum exposure of 1000 seconds (IIa). Again this hazard increases with the use of optical aids. Class IIIa lasers are Class II lasers that cannot be viewed with optical aids. Lasers

of Classes I, II, IIIa, and IIIb are lower powered lasers. Class IIIb lasers are medium powered lasers, whether visible or invisible. Class IIIb lasers may cause eye damage from either intrabeam viewing or specular reflection. Higher powered IIIb lasers may cause skin damage and diffuse reflection may cause eye damage for certain wavelengths. Class IV lasers are high powered lasers, visible or invisible, that can cause immediate and serious damage to the skin and eye by either intrabeam or reflected exposure. Class IV lasers also pose a fire hazard and are capable of producing byproduct emissions, known as Laser Generated Airborne Contaminants (LGAC) from the target material. Overexposure to ultraviolet light can cause health hazards such as sunburn, skin aging, and skin cancer. Exposure to high powered infrared light can cause thermal burning of the skin. Non-beam hazards may include electrical shock and exposure to hazardous chemicals.

5.3 ANSI Z136.3 - Safe Use of Lasers in Health Care

ANSI Z136.3 Safe Use of Lasers in Health Care provides processes to protect any person who may be exposed to non-ionizing laser radiation in healthcare applications. These applications may include instances where lasers are used for the diagnosis of disease, bodily structures or functions are altered, and any other application in which lasers are used for healthcare purposes. Operating manuals for these lasers must include instructions for assembly, calibration, operation, and maintenance. Included should also be instructions for preventing hazardous laser exposure, including protective eyewear. The control measures of ANSI Z136.3 are in place to protect the patient, public, and personnel operating the lasers.

5.4 ANSI Z136.8 - Safe Use of Lasers in Research, Development, or Testing

ANSI Z136.8 describes the Safe Use of Lasers in Research, Development, or Testing. As an addition to ANSI Z136.1, this standard details hazards of the laser beam path and beam interaction; control procedures in restricted, unrestricted, and various other locations; and information on eyewear for alignment, export controls, warnings signs, etc. This standard applies to locations such as universities and research labs where lasers are used for research, development, and testing.

5.5 ISO/TC 172 - Optics and Photonics

The International Organization for Standardization (ISO) catalogue of standards ISO/TC 172 is specifically for Optics and Photonics. The standards (ISO/TC 172/SC1, SC3, SC4, SC5, SC6, SC7, SC9) apply to fundamental standards, optical materials and components, electro-optical systems, and others. The subsets of these sets are broken down into individual standards for optics and photonics. For example, ISO 10110-10 defines how to tabulate data regarding optical elements and assemblies as preparation for optical drawings.

5.6 IEEE STD 1-2000 - Temperature Limits: Rating and Insulation

IEEE STD 1-2000 is the IEEE Recommended Practice-General Principles for Temperature Limits in the Rating of Electrical Equipment and for the Evaluation of Electrical Insulation, a series of recommendations that will help guide the design goals of reducing hot spots on the device and making sure that no system elements are overheated. These standards help to guide the design so

that it is electrically safe, offering points of reference and specifics to look for while choosing a safe temperature range.

The standard first introduces general concepts to consider. Two overarching theories should be followed: the ambient temperature is unlikely to stay at a maximum or minimum for a long period of time, and that load cycles may contain moments when the load is not at the typical rating [25]. These principles remind the engineering team to keep in mind that the system will not always be ideal, so leeway must be considered in specification designs. It would be insufficient to assume that ideal temperatures and functionality will always be achieved. The standard explains that temperature is not measured directly in one specific place. Instead, “The permissible temperature rise is generally specified, therefore, to be less than the difference between the temperature recognized in this recommended practice (Table 1) and the temperature of the ambient air or other cooling medium,” [25]. In order to find the temperature of the system, one could employ one of the following suggested techniques: resistance, embedded temperature detector, applied thermocouple, contact thermocouple, or simply use a thermometer [25]. The temperature measurement standard suggests finding a way in the design to cool or maintain temperatures. This consideration is important in the design of the casing for the team’s Raman spectrometer. The following table includes values suggested by IEEE STD 1-2000 for potential rises in temperature in a system. Of these values, a change in temperature at a value between 30 °C and 35 °C would be ideal as a maximum change, especially considering that someone will be holding the probe for the spectrometer and that a large jump in temperature could pose a problem for safety constraints and specifications. A temperature change within these values would not be a problem for the system requirements. While system requirements are important, all safety considerations must take priority. The L.A.S.E.R.S. Raman spectrometer should not cause harm to anyone using the system, else the purpose of the project would be lost. For the specific application and purpose of this project, only the lowest values on the table below would be acceptable.

30	45	75	100	130
35	65	80	115	140
40	70	90	120	150

Table 2: Data from [25], IEEE STD 1-2000, in degrees Celsius

Material temperature limits are important to consider. In choosing the filament for for casing material, it is important to note that most materials do not immediately go from a solid to liquid at the melting point. The standard states that, “In these cases, the functionally important softening temperature, which is generally known as the glass transition temperature, may relate to the mechanical stresses imposed in service and the amount of deformation and creep that can be tolerated,” [25]. Thus, it is perhaps more important to be aware of the glass transition temperature than the actual melting temperature. The glass temperature is lower than the melting point, and any shift in the stability of the material used for the casing could be catastrophic for the built Raman spectrometer. It is essential that the fragile parts of the system are stable and protected within the casing; no decay from the solid point of the material must occur in order to meet the goals of the design specifications. Thus, the glass transition temperature will be an important feature to understand when choosing the filament for the casing of the L.A.S.E.R.S. system.

Next, within the standard, considerations to prepare to choose a design standard are discussed. In general, the purpose and functionality of the product must be considered when choosing design specifications. The standard recommends that, “In considering such factors, predominant conditions rather than extreme requirements should be used as a basis for standards,” [25]. For the design of this Raman spectrometer, the device must be able to be used daily, potentially multiple times a day. The device will sit in a room that will have air conditioning, set to a value between a range of 68 °F (20 °C) and 78 °F (25.56 °C). Assuming the maximum allowed change in temperature, 35°C, the maximum temperature of the Raman spectrometer will be approximately 141.008°F (60.56°C). Therefore, the material chosen for the casing must have a glass transition temperature above 60.56°C in order to be acceptable. A consumer would expect the device to last for years as it is an investment. Therefore, longevity must be considered as well as how the device elements will heat and be impacted by heat with daily use.

5.7 IEEE STD 1241-2010

IEEE STD 1241-2010 is the IEEE Standard for Terminology and Test methods for Analog-to-Digital Converters. This standard may be applicable to analyzing and processing the data received by the sensor array. The standard discusses important considerations for testing analog to digital converters as well as important concepts essential to fully utilizing a designed system. These guidelines will be useful for the part of the system that consists of the microcontrollers and the sensor apparatus. This standard is written specifically to cover signals that have already been both sampled and quantized [26]. Therefore, the team must be able to confirm conditions to follow the standard must be met.

First, IEEE STD 1241-2010 discusses important background information on the topic of analog to digital conversion. The standards states the importance of understanding the designed system. It is essential to fully understand the requirements for each element of the system. As described in the standards, “The user should fully understand the manufacturer’s recommendations with regard to proper signal buffering and loading, input signal connections, transmission line matching, circuit layout patterns, power supply decoupling, and operating conditions. Edge characteristics for start-convert pulse(s) and clock(s) must be carefully chosen to maintain input signal purity with sufficient margin up to the analog input pin(s),” [26]. Thus, in order to make successful design constraints, the team must turn to the datasheets for each major component to determine what is required.

Understanding how to go about troubleshooting an analog to digital conversion system is essential to verify that the system is functioning properly. There are two ways to analyze errors found within an analog to digital conversion system [26]. As with any electrical system, it is important to understand common pitfalls of a project to figure out which troubleshooting method(s) is/are most applicable. One could either analyse the code using the code center error analysis method, checking the signal at the middle, or the code edge error analysis method, checking the signal at the edges [26]. When testing devices and systems for functionality, it is important to check for any information given with those objects. If any conditions must be considered while testing, they must be followed to successfully analyze. As stated in the standard, “Since the test condition ranges are generally specified in continuous intervals, they describe an infinite number of possible test

conditions, which obviously cannot be exhaustively tested. It is up to the manufacturer or tester of an ADC to determine, from design knowledge and/or testing, the effect of the test conditions on the test result, and from there to determine the appropriate set of test conditions needed to accurately characterize the range of test results,” [26]. In order to successfully follow IEEE STD 1241-2010, the team must be sure to verify any suggested conditions for device operation. The team must also fully understand any information given in the datasheet about system/device requirements and make sure that, at all times, these specifications are met during the testing and development process.

5.8 Coding Best Practices

Coding does not have the standards most other engineering discipline have established, but the need for best practices allows for improved readability of the software, which allows it to be understood more quickly. Also, as this is a part of the product, it should be something that is as well packaged as any other component of the project. These considerations allow for the maintenance of the software to be performed with more ease through the lifetime of the code.

5.8.1 File Organization

Each programming file should contain sections that should be separated by empty space, with use of a comment identifying each section. This allows anyone viewing the code to have an idea of what to expect from this piece of code, as well as which code fragments can be separated. Comments are a vital part of this, giving the user an idea of what datatype should be input to each method, what will take place and computed, and what to expect in return.

5.8.2 Declarations

Declarations are implicit in coding, and help in the spacing of the file, as well as in the safety of the data. In Java only one variable declaration per line is recommend, as to reduce comment confusion. Also it is recommended to keep declaration naming functional to provide a reminder as to what data or method it is performing. Method and class declarations should have no space between the method name and its parameter list, and the open brace and close brace should exist in the same virtual column for easy viewing.

5.8.3 Statements

Statements are the basis of a program, and their associated best practices allow for a user to follow the flow of the program from line to line. If there are multiple statements on a single line, the results are a program that are unreadable. Each statement should be followed by a semicolon, which indicates the completion of a single statement. For conditional and loop statements, several rules apply, which will result in a syntax error if not followed. Examples include: If must be followed by else, fors must have initializations, condition, and update statements, and each try statement should also be followed by a catch. These will prevent logical breaks that can result in broken code with certain conditions.

5.9 Power Standards

The team may need to investigate additional standards related to power consumption and the use of a wall outlet as a power supply. The team is awaiting guidance and feedback on the best way to power the device as well as maintain that power to the proper device modules. Once exact details are determined, then the related standards will be investigated, if needed.

6 Project Constraints

Project constraints are the limits put in place by the design team to fully understand what the final device must deliver and any details surrounding the implementation of the final design. Some constraints, such as time and cost, are beyond the control of the team and add to the challenge of the final deliverable. Other constraints consider general safety and usability goals. The device must appeal to an audience, whether a patient, medical professional, or other engineers, in order to be considered a success. The Project Constraints ensure that the goal of the final L.A.S.E.R.S. device is always considered throughout the design, construction, and implementation processes.

6.1 Design Constraints

Working with medical technology and optics brings a challenge of specific design considerations as well as safety protocol that must be followed. Considerations must be made in order to meet the cost and design goals that allow the final product to be accurate, safe, and reliable. This project considers each design specification individually and as they contribute to the complete system. The following design, engineering, and safety goals define the focus of the research process and the overall goals of the project.

6.2 Time Constraints

While the idealistic goals of the project are to create a device of similar quality of something found on the market, there are constraints to consider that limit the final product to a device that would be considered a prototype. The total length of time to design and build a Raman spectrometer, on little funds and experience in comparison to a corporation that regularly builds similar devices, greatly impacts the scope of the project. The final product will meet all standards, constraints, and the mission for the L.A.S.E.R.S. project; it would be unrealistic to expect a device that looks immediately ready to be sold. The heart of the project, as well as the theory and logic behind the goal of potential cancer detection, will still hold despite constraints of time and funding.

There are four major time constraints that must be considered: time to research and design, time to get the required parts, time to build, and time to demonstrate the device. The time to research device requirements, choose specifications and constraints, find applicable technical specifications, design the device, and write this document is approximately fourteen weeks. This time is utilized by each member of the team focusing on their specific area of specialty and interest. While the team works together and all members are equally present in the design and research process, it is more efficient for each member to have a focal point to be the team expert for a

specific part. It is important to note that this time must also consider time spent testing potential parts for the project to see if they meet specifications.

A difficult constraint to work with is the time to procure a required piece for the Raman spectrometer system. This challenge ties in with economic constraints. Most of the parts required, such as microcontrollers, the filament used for the casing, and the CCD array, can be purchased and delivered in a reasonable amount of time, less than two weeks, for under \$70 each. Elements that are more complicated, such as the laser, grating, lenses, printed circuit boards (PCBs), and the 3D printed casing, take more time and money to procure. Both the PCBs and the 3D printed casing must be sent out to a facility that will realize the designs made by the team. On average, it may take up to two weeks to receive the final PCBs and two weeks to receive all 3D printed parts for the casing. Optical pieces provide the challenge of being the most expensive part of this project. The team would like to find a sponsor or borrow most, if not all, optics parts, and thus the time to find these partnerships must be considered. The balance of time and money is a complicated challenge that must consider the benefits and risks of waiting to find a partnership and paying hundreds of dollars for the parts from the team's own funds. The benefits must outweigh the risk.

The time needed to build and construct the L.A.S.E.R.S. system once all necessary parts are purchased or donated will last from the end of Senior Design 1 through Senior Design 2, approximately 13 weeks. During this time, all items required must be in hand and ready to put together. All electronic parts must be connected and soldered onto the PCBs. All optical parts must be placed in their proper arrangement. Each portion of the device will be assembled individually and verified as functioning. Once all of the physical hardware pieces are in place, then the software portion of the project can be tested and verified. This integration is the key to the success of the project. The assembly portion of the project includes the physical building of the device as well as the testing of the individual parts within the whole. Once each portion is verified, then the testing process of the L.A.S.E.R.S. system as a whole can begin.

Lastly, the final demonstration at the end of Senior Design 2 is the ultimate goal of the project, and time to demonstrate the device is a necessary constraint. The full presentation lasts a total of 20 minutes, with 10 of those minutes to demonstrate the product created. Given that the device is not automatic, that someone must scan the object or sample in question, time needs to be considered to physically demonstrate the Raman spectrometer. Thus, the actual process of scanning an object or sample and receiving data must be completed in less than 5 minutes.

6.3 Health Constraints

The health and safety of the user and the patient must be considered as priority for this device design. Thus, the focus should be placed on reducing exposure to the laser, making sure that no hot spots exist, and no sharp edges are in the plastic casing. The plastic casing will be enclosed around all electronic and optic parts to prevent stray light from affecting results and to prevent eye damage for both the user and the patient. The casing will be a heat-resistant plastic wrapped with lead foil to prevent exposure. In order to increase the attractiveness of this option to a patient, sample time must be relatively short. Sample exposure time should be less than 30 seconds. An analysis time with a five minute maximum is ideal, as the sample is theoretically on a human.

A major benefit of the design and application of this Raman spectrometer is that, compared to typical biopsies, this device is a non-invasive tool to check for potential cancer cells. Therefore, this device should not leave any physical marks or cause any pain for the patient. This should be an attractive device with its improvement for the patient experience as a major selling point. There should be no risk to the patient for having this form of testing performed on them, especially in comparison to a biopsy. Biopsies are invasive and require collecting skin cells, while the L.A.S.E.R.S. system only requires the cells on the skin, or the testing sample, to be read by the probe.

6.4 Economic and Cost Constraints

The overall spectrometer system must be cost efficient for the potential user of the device. The goal is for the device to be under the cost of five biopsies, roughly \$1,500. This cost constraint is not only necessary for parts that the team must pay for, but also to justify the device to a patient or physician. In any market, an updated device should be either more effective or more cost efficient in order for consumers to justify making the purchase. This constraint allows for flexibility in the consumer of choice. There are two potential consumers for this device: a patient with a higher risk factor for skin cancer and/or a physician's office. For a patient, the price point should cost less than the five biopsies and any other potential costs for going into a physician's office, such as a copayment or other office fee. For the physician, the price point should be less than the cost of any lab, processing, and shipping fees to send out many biopsy samples for a multitude of patients. For the team to build this device, it should meet expectations of the budget for four college students. While the team hopes to receive parts via donation, the ability to borrow, or a sponsorship, these are not guaranteed and therefore the worst case scenario of having to pay for all parts of the system must be considered. The economic and cost constraints are vital.

6.5 Size Constraints

The Raman spectrometer will have a compact size to more easily analyze skin at different locations on the body, while still attaining high throughput. The size of the overall system is not to exceed what is reasonable for a typical desktop space found in a doctor's office. The dimensions of the completed system must fit within a 2.5' by 2.5' space. The main body of the spectrometer will contain the CCD array, microcontrollers, and power connectivity, therefore these parts will determine the minimum size of the device. As long as the design is streamlined and efficient, the size will fit this constraint. The size and design of the casing must also consider heat flow. There must be an attractive and ergonomic overall design for the users of the system. The part of the device that contains the laser and would be applied to the patient's skin/the sample must be large enough to hold the required electrical and optics pieces. This same part must be small enough for the user of the device to comfortably hold in their hand. The comfort of a potential patient must also be considered, and therefore the size must not be too large to comfortably fit on the sample.

6.6 Temperature Constraints

To ensure that the system is operating safely, the temperature of the system must be monitored. This is to ensure that that laser, optical elements, electronic elements, and the casing do not reach a temperature near the glass transition temperature, as discussed in IEEE STD 1-200 is the IEEE

Recommended Practice-General Principles for Temperature Limits in the Rating of Electrical Equipment and for the Evaluation of Electrical Insulation. Material selection for the outer casing must consider the heat distribution of all electronic and optical parts. The overall heat of the system must not exceed 71.2°C (140°F), a value that must be below the glass temperature of the casing filament.

6.6.1 Heatsink Design:

Temperature plays a vital role in ensuring data accuracy and reliability in our system. For most of our components, very little heat will be generated. However, the two most vital components, the laser and the Raspberry Pi, will be located in a small enclosure with one another. The amount of thermal radiation given off by these two devices is the majority given off by the entire system, and these two systems reliability and accuracy can be directly affected by it. To offset some of the heat given off by the system, we will be designing a heat sink which will pull the heat away from these and allow the units to operate at maximum efficiency for the duration of our tests. [27]

Heatsink design uses several important parameters:

1. Thermal Resistance
2. Airflow
3. Volumetric Resistance
4. Fin Density
5. Fin Spacing

Due to these parameters, and the given design of our system, we will only really have control over material selection, fin density and spacing, as well as the length and width constraints outlined by the design.

The overall heat sink design will be made to fit inside the casing around the Raspberry Pi and the laser. The material we will be using will be aluminum due to its low cost, easy to CNC attributes, and its light weight.

The heat sink design for our project will be similar to that that comes with the Raspberry Pi in a typical fin design. Our intention is to use whatever space is necessary to ensure stability of our systems, while staying in a portable form factor.

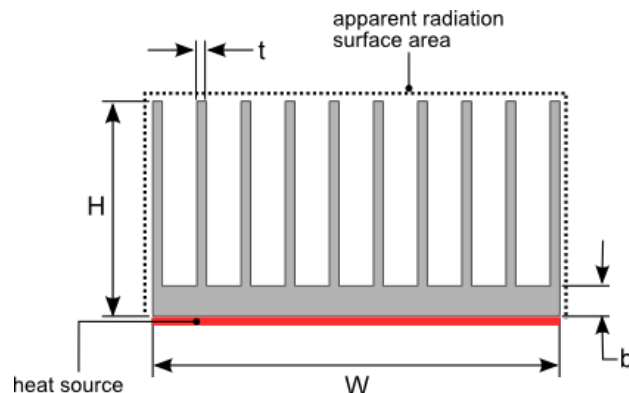

Figure 6: Heat Sink Template

6.6.2 Material Selection

Material Selection is one of the most determinant ways of thermal management of our microcontroller systems. The selection of materials for our system requires us to consider the functional requirements for each individual component in the system. After following the Ashby method for material selection, which takes into consideration the attributes such as density, strength, cost, resistance to corrosion, and others that we may find beneficial to our projects planning. For our needs, we have identified two possible metals that serve our project specifications.

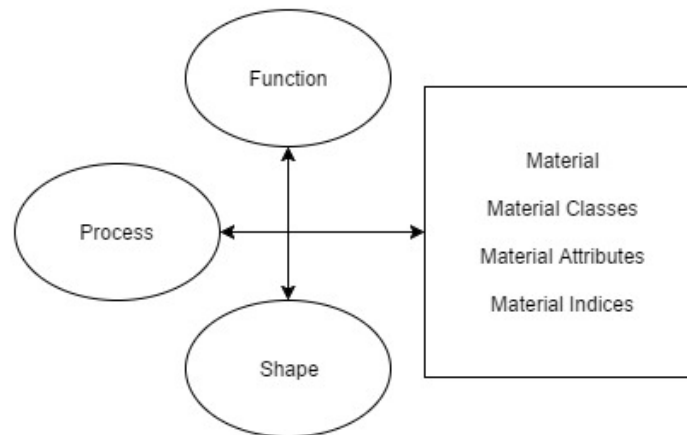

Figure 8: Heat Sink Design Constraints

Aluminium:

Cost: 1.91 USD/kg

Density: 2.7 g/cm³

Thermal Conductivity: 205.0

Copper:

Cost: 5.76 USD/kg

Density: 8.96 g/cm³

Thermal Conductivity: 385.0

6.6.3 Active Cooling Design:

At this time, we have no intention of an active cooling solution, but if the heat dissipation requirements end up calling for it, we will be designing a small air flow port and a place to put a small fan to be able to move air across the heatsink. If an active cooling solution is deemed necessary, the fan will be controlled by the Raspberry Pi, using temperature sensors which will be constantly monitoring the status of both the laser and the Raspberry Pi.

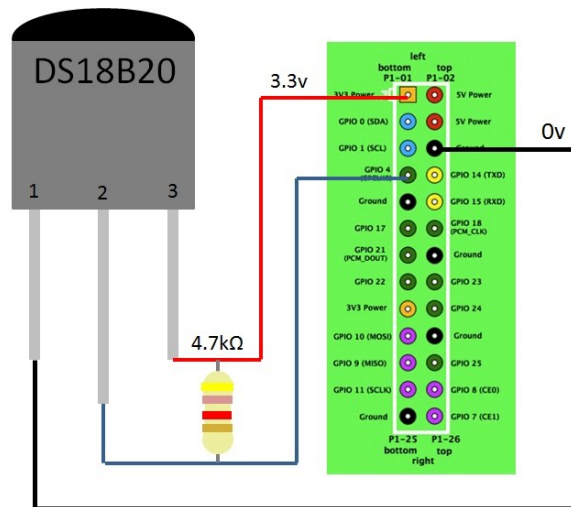

Figure 9: Temperature Sensor

Fan Selection:

Though fan selection may seem like an arbitrary task, there are several ideas to take into consideration while selecting a fan. These considerations allow for optimal airflow through the system which greatly reduces the necessary run time for our active cooling fan.

Fan Size

Currently this is the largest determining factor for our fan. The larger the size of fan allows for more air movement, As the size of the diameter of the fan increases, each fan blade will increase by a factor of $\frac{1}{2}$, which when extrapolated over the 4-6 fan blades will result in a vastly increased amount of air moved. The negative to a larger fan is the increased package size, which when creating a platform designed to be useable at home is not ideal. These parameters should be balanced to an provide an optimal experience.

Air Movement

Fans of a similar size will indicate different varying measurements of air movement, which is largely determined by blade shape, and maximum rotations per minute (RPM). Though in a pure cooling sense more air movement is ideal, the other desired traits of the project will also play a key role in determining optimal air movement. Fan shape largely determines air pressure as explained below, and RPM greatly increases power consumption, ambient noise, and vibrational considerations of the project. It will be optimal for us to select an RPM dependent setup as to vary the air movement as it is needed.

Air Pressure

Though a fan moving more air is typically determined by only air movement, the fans ability to move air under pressure is also a large consideration for our project. Air resists movement naturally, but when the air must be pushed past the fins of a typical heat sink array, the static pressure of the air builds up. Increasing the amount of air moved does not necessarily move this air, and it creates a buildup of heat in the system. A fan with a large resistance to static pressure will be ideal in our situation, since we will be moving the air in an enclosed space, with many objects inhibiting its flow.

6.7 Sensor Constraints

The collection optics sensor, either a CCD or CMOS array, will receive the scattered light effectively. It must be able to account for at least 40% of received light in order to be accurate and effective. The chosen sensor must be able to accurately pick up light emitted from the Raman spectrum at the wavelength of choice. Size and economic constraints greatly impact the choice of sensor. For proof of concept, receiving greater than 40% of light will suffice. With more funds to work with, ideally the sensor would take in at least 80% of the emitted spectrum. This percentage may increase depending on the wavelength of interest, which depends on the chosen laser.

Another important requirement is that the chosen sensor must be able to communicate with the rest of the system and be easily accessed. It must be a simple enough array that the collected data from the sensor can easily and quickly be taken in by attached microcontrollers, and then displayed on the user interface within a reasonable amount of time. The more simple and effective the specific sensor array, the better for this application. A smaller sensor will also be useful to reduce cost and be easier to protect within the casing of the body of the Raman spectrometer.

6.8 User Interface Constraints

To tie in all the data found, the spectrometer must have an attractive and user friendly user interface. Software must accurately and reliably analyze the Raman spectra of the scattered light read in with a sensor. Ideally, the designed user interface will have the ability to run on a variety of market available devices, such as a laptop or tablet, so that there is an increased accessibility for potential users of the system. It is important that the user interface offers both ease of use and a simple appearance, all while delivering information that a patient and/or medical professional can trust. It must be simple enough that someone not trained in medical sciences could interpret the results easily, and take the advice of if the trip to a doctor will be worth it, while being informative. The user interface must be simple, options must be clearly labeled, with simple guiding steps on the procedure to test presented to the user in a straightforward fashion. It is essential for the L.A.S.E.R.S. system to be informational without oversharing complicated data.

6.9 Optics Key Design Constraints

The optical components of the system must consider both functionality and size. The focal lengths of the optics (mirrors and/or lenses) must be reasonable so that the spectrometer is relatively compact. The laser must be relatively stable to avoid mode hopping. Mode hopping may cause an error in measuring the Raman shift. The bandwidth of the laser must also be narrow (only a few nanometers) in order to have sharp Raman peaks. Because the intensity of the Raman signal is inversely proportional to the excitation wavelength ($1/\lambda$), a shorter wavelength is generally more powerful. However the fluorescence of organic molecules must be accounted for because it can overwhelm the Raman signal. Laser excitation wavelengths of 785 nm to 830 nm (NIR) are typical of Raman spectroscopy of biological tissues. The output power of the laser necessary to obtain Raman signal can be less than 350 mW. Spectral ranges of typical studies of normal and cancerous skin are from 400 to 1800 cm^{-1} , which corresponds to a wavelength range of approximately 810 to 915 nm. This range captures the spectral peaks of certain proteins and lipids that make up skin that will be used to classify and diagnose the sample. A resolution of 6 to 11 cm^{-1} is sufficient for

resolving the spectral peaks for the determination of cancer. Of course a resolution smaller than this is better. We are aiming for at least 70% sensitivity and 70% selectivity.

There are several important parameters and constraints to consider when designing the Raman spectrometer according to Butler et al. Considerations include identifying the purpose of the Raman system, knowing the constraints of the sample, the laser excitation source and interaction with the sample, the detector to collect the spectral data, resolution of the spectral data, and various optical elements such as filters, the aperture, and microscope objective. Furthermore the system will require calibration and data processing. [11]

First is the need to identify the investigative aims and analytical goals of the Raman spectrometer. L.A.S.E.R.S. will be a diagnostic tool, using the “fingerprint” of the Raman spectra for spectral classification and diagnosing of the sample. [11] The samples to be measured will have characteristic peaks at certain wavelengths based on the vibrational energy modes of the material. These peaks will be used to determine the composition of the sample, specifically whether the skin sample appears to be normal or cancerous. To remain within a reasonable scope of the project, the Raman spectrometer will be able to identify normal skin cells versus skin cells exhibiting spectra indicative of basal cell carcinoma (BCC).

Second, the constraints of the sample must be considered. The sample will determine the laser excitation wavelength, power and intensity of the beam, beam spot size, and acquisition time. It is the goal of L.A.S.E.R.S. to examine *in vivo* the Raman spectra of human skin. Therefore the safety of the human subject is of utmost importance. The University of Central Florida Institutional Review Board (UCF IRB) is “a committee established to protect the rights and welfare of human participants involved in research.” A benefit of Raman spectroscopy is the minimal sample preparation needed. Samples can be superficially cleaned with a wipe. The optical focus of the setup simply needs to be maintained, which is simple for samples with a relatively flat surface. The sample must be suitable to withstand the incident photon energies without becoming photodamaged. The incident photon energy of 785 nm wavelength is usually low enough to reduce the risk of damage to a sample.

Third, the excitation source plays a role in the interaction of the sample and resolution and sensitivity of the system. The type of laser source, desired excitation wavelength, and desired spot size are important factors in considering what source to use. Diode lasers are commonly used because of their efficiency and long lifetime. Their durability and compactness is of interest because L.A.S.E.R.S. is meant to be portable. Using a NIR or UV wavelength will reduce the fluorescence of the sample, increasing the spectral quality. The linewidth will also directly affect the spatial and spectral resolution of the system. The intensity of the Raman scattering signal is inversely proportional to the fourth power of the wavelength as represented by the equation $I=1/\lambda^4$. Intensity is defined as the ratio of the power of the beam to the area of illumination. Therefore the intensity is dependent on the beam spot size. Intensity is also dependent on the magnification of the beam. The magnification will be determined by the optical element(s) used and its numerical aperture (NA). Keep in mind that, as mentioned previously, the sample must be able to withstand the wavelength, intensity, and temperature increase resulting from the laser source. In summary, the spot size and sensitivity of the system depend on wavelength, and the spatial resolution depends on the spot size.

A fourth consideration in designing a Raman system is the optical and electrical elements to be used for measurements. L.A.S.E.R.S. will use a fiber-optic probe to act as the focusing and collecting optics of the light. A probe will allow the system to be modular, portable, and comfortable to use. Optical fibers will distribute the power of the laser beam spot size over the sample resulting in higher spectral quality. Filters will be used to select the wavelength(s) to be collected and analyzed, filtering out the Rayleigh scattering and allowing only the Raman scattering. Holographic notch filters and dielectric edge filters are two options. Edge filters will allow the transmission of wavelengths above the laser excitation wavelength, while notch filters transmit only the excitation wavelength. The transmission wavelengths allowed determine whether Stokes and/or Anti-Stokes measurements are possible ($E=hc$). A slit or pinhole, typically ranging in size on the scale of microns, can be used as an aperture to control the wavelengths allowed into the system. The size of the aperture depends on the balance between the amount of light entering the system and the spectral resolution. For instance, a larger aperture will allow more light, increasing the Raman signal intensity, but will reduce the the spectral resolution.

Lastly, calibration and data processing of the Raman system will be required. Calibration involves laser beam alignment with the optics and fitting the spectral peaks of the signal to particular pixels of the detector. Butler et al. suggests silicon as one reference material because of its sharp peak at 520.5 cm^{-1} . The data processing of the spectra involves some pre-processing in addition to the spectral classification. Data pre-processing techniques, such as Principal Component Analysis (PCA) and normalization, will be utilized to remove outliers and spectral peaks caused by cosmic rays. Cosmic rays appear in spectral data as sharp peaks with very narrow linewidths. L.A.S.E.R.S. will specifically measure over the range of wavelengths containing the spectral peaks of normal and cancerous skin. This limited range of wavenumbers will help to reduce the amount of data to be processed. Then PCA or other machine-learning techniques can be utilized to classify the spectra compared to a database of typical spectra for a specific sample type.

6.10 Health and Safety Constraints

UCF Institutional Review Board

In order to use human skin samples or human subjects for testing our Raman spectrometer, the University of Central Florida Institutional Review Board (UCF IRB) would require the team to obtain the proper clearances and complete the appropriate documentation. The UCF IRB would require the team to request an iRIS user account and submit an application to conduct our study. Approval by our faculty advisors and then by a director or department chair follows. In order to meet federal regulation guidelines, the team would need to undergo CITI training. It is important to note that CITI training must be completed by all investigators involved in the study before IRB approval can be obtained.

The team contacted the UCF IRB to determine what documentation must be submitted in order to conduct our research. Particularly for our project, the team would have to create a research protocol as required by the form HRP-503: Human Research Protocol Template and Instructions, and form HRP-502a: Consent - Adult. Due to the administrative clearances and time constraints, our team has decided to investigate alternatives to human skin, such as pig skin.

UCF Institutional Animal Care and Use Committee

The UCF Institutional Animal Care and Use Committee (IACUC) is a part of the Office of Animal Welfare. The IACUC requirements for using animals in research states the following: “If the study involves only tissues that are specifically acquired from a live or deceased vertebrate animal solely for research purposes or from another agency, investigator, institution, or a commercial vendor, a protocol *may* need to be filed with the Office of Animal Welfare and approved prior to implementing the study.” The Office of Animal Welfare was contacted in order to determine if IACUC approval is required to carry out this project. The pig skin samples may be purchased from a local butcher shop. Because the samples would originate from a dead animal, the Office of Animal Welfare has deemed that our project will not require IACUC approval. As a contingency to pig skin, we may prepare samples at differing concentrations containing select proteins and lipids present in normal and cancerous skin.

6.11 Overall Functionality Constraints

Successful functionality means that the overall system must be reliable, deliver a faster diagnostic response time, be accurate enough to replace a biopsy, and be safe. L.A.S.E.R.S. will boast efficient design that allows for simple and effective troubleshooting with just as simple and effective use. Low and efficient power consumption and distribution is essential. In general, no power will be distributed to an element in the system that is not required. The data transfer must be fast and secure, offering quick but efficient information about the tested sample or patient. An important limit to keep in mind is that results must be collected and viewable within the time limit of the final presentation, approximately ten minutes at maximum; ideally this time period will be less than five minutes.

6.12 Printed Circuit Board Constraints

PCB constraints exist in virtually every procedure in which it is fabricated. From the initial circuit design that was simulated up until the final stages in component mounting, the PCB will have to be properly made and revised to ensure optimal consumption with little to no performance loss. If the initial designs or fabrication are done incorrectly, then there will be a delay and could alter the date of completion. In this project, there will be multiple PCB's, each with their own dedicated task to complete the primary objective. Understanding the constraints for each PCB is necessary to ensure that the design upholds its performance marks.

From a chronological view, the first constraint that is encountered when focusing on PCB's is their design schematic. Considering that this project will require two or more PCB's, the immediate concern is powerflow and interconnected design. It is understood that this design needs to remain modular, which does help for troubleshooting and heat concerns, but it can also make it more difficult to interconnect and communicate between each PCB. It also will require more connections, which may end up being more costly and more fallible. The main constraint in the design schematic is time and efficiency; the circuit must be tested at every level, from the computer simulation through to the breadboard simulation. If at either of those junctions the PCB does not yield the result needed, then it will need to be redesigned and reconfigured [28].

In the following stages of the PCB design, the next constraint is related to the software in which the PCB will be created. To ensure that the PCB is done correctly, there has to be proper documentation and corresponding drawings that match with the design needed. For example, if the Gerber Files that were extrapolated from the software for the first PCB do not properly allow for the microcontrollers to mount on top of them, then the drawings need to be recreated to ensure functionality.

After creating a properly working schematic, the question that needs to be answered is which type of PCB layout is needed. Looking at the design of the project itself, the PCB's cannot be too large or too small due to size and component constraints. If the PCB's are too large, the overall spectrometer design loses its reputation for being mobile. However, if the PCB 's are too small, then the surface area of the PCB decreases, meaning that the PCB loses its capability to have more components attached to its surface. The conditional constraint here is to find a layout that would enable each PCB to be small enough to maintain the overall modular-yet-compact design while maintaining its performance capabilities.

The next constraint that needs to be addressed is regarding component placement and fine tuning. The common complications in placing the components is the potential for interferences, ranging from thermal pollution, noise, and functionality. The PCB's will need to be carefully examined for the temperatures of the components, their susceptibility to noise, and potentially redesigned and rewired for better functionality.

7.0 Project Hardware and Software Design

One concept for the design of the L.A.S.E.R.S. system is shown in **Figure #**. The major components of the system - laser, spectrometer, and electronics - will be housed in an area no larger than a desk space of 2.5' by 2.5' in order to keep the system compact and portable. An optical fiber will carry the excitation light from the laser to the Raman probe. The probe will be lightweight and handheld so that measurements can be taken at several points on the body. Another optical fiber will carry the collected light from the probe to the spectrometer.

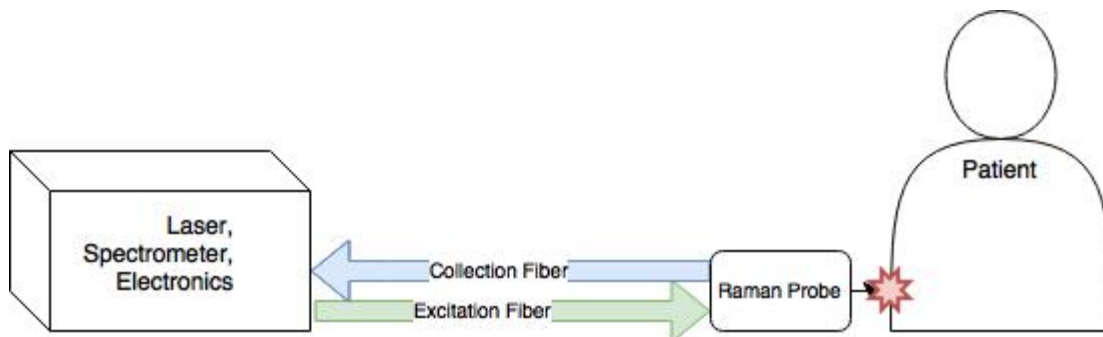

Figure 10: Design Concept for the Raman System

7.1 Printed Circuit Board (PCB)

The L.A.S.E.R.S. system will include multiple printed circuit boards (PCBs). In total there will be three PCBs. One PCB could be designed and utilized to control all major aspects of the system, however this setup may be less beneficial for this system. First, multiple PCBs will allow for the design team to focus on specific elements and keep like parts together. It will also help secure certain circuit elements, such as the fragile glass on the sensor array. Keeping fragile elements on a separate CCD will allow for a certain space to be designated for it in the casing of the device, reducing the chances of damage to the device. A modular, streamlined design will also improve the troubleshooting process. Should an element of the system fail, it would be more difficult to quickly and effectively troubleshoot a PCB connected to every element of the system. If a problem exists only in one portion of the device, the team can more easily pinpoint that something must be wrong within that element. A focus on modular design is key to simplifying design and functionality.

There will be one PCB for each major section of the device. The first PCB will maintain and deliver power to the system. This PCB will take in power from a wall outlet and connect it to the CCD apparatus, the laser, and the microcontrollers. The second PCB will hold the CCD apparatus to maintain the devices functional integrity. By making a dedicated PCB for the CCD, the device will have minimal thermal pollution and noise, restricting fallibility. Finally, the third PCB will provide any circuitry needed for the microcontrollers, such as any filtering or modulation.

The PCB layouts are still a topic of discussion amongst the group. The main task is to create PCB's that can interconnect with one another and provide enough power throughout the system all while meeting size, cost, heat, and component constraints. Since the system will be modular and have multiple PCB's committed to only a few components, there is a thought that having multiple layers may not be necessary to effectively run the system. In effectively cutting out PCB layers, the cost will decrease as well as the heat within the PCB.

7.2 Probe Design

A lightweight, handheld probe will allow measurements to be easily made at any location on the body. The probe should be placed at an angle normal to the skin for maximum signal collection. To implement this, optical fibers can be utilized to direct both the excitation and collected light between the sample and spectrometer. More detailed information is given in the section on optical fibers. A possible setup for the probe is that as used by B&W Tek, shown in **Figure #**. The excitation light from the optical fiber is collimated by a lens to be passed through a bandpass filter in order to narrow the laser line. The laser light is focused onto the skin/sample using a lens. This same lens can act as a collector of the reflected light. The dichroic filter transmits the excitation light but reflects the collected light to a mirror. The collected light is then passed through a long-pass filter to block the laser line (Rayleigh signal) allowing only the Raman signal to be directed to the spectrometer. Note that a short-pass filter or notch filter can achieve the same results. A third lens couples the collected signal into the collection fiber, which is connected to the spectrometer.

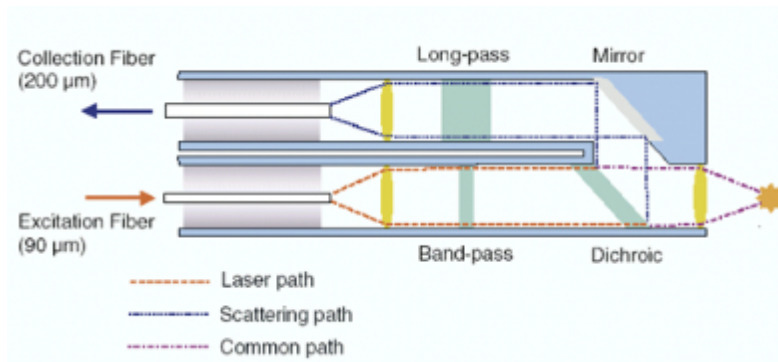

Figure 11: B&W Tek Raman Probe Design (Permission Granted)

7.3 Spectrometer Design

The spectrometer is the portion of the Raman system that disperses the Raman signal into its constituent wavelengths in order to measure the Raman shift. In its simplest form, the spectrometer will be comprised of an entrance slit, collimating and focusing mirrors or lenses, a diffraction grating, and the detector. The size of the entrance slit determines the divergence of the light into the spectrometer to be mapped onto the detector, which in turn determines the optical resolution of the spectrometer. If using an optical fiber to couple the input light into the slit, then stacking or bundling fibers will help to match the dimensions of the slit. The image of the entrance slit should be larger than the pixel width of the detector for high resolution. A collimating lens or mirror will collimate the light onto a diffraction grating. The diffraction grating disperses the light into its constituent wavelengths, determining the spectral range of the system. Then a focusing lens or mirror will focus the dispersed light onto the detector.

7.3.1 Laser Excitation Source

Near infrared wavelengths of 785 nm and 830 nm are commonly used when working with biological materials because of low IR absorption and reduced fluorescence interference of the materials at these wavelengths. We currently have access to a Helium-Neon laser (632.8 nm) and a Thorlabs 635 nm laser diode (shown in **Figure #**). After further discussions with Ocean Optics and OptiGrate, we will know if we will have access to other laser sources.



Figure 12: Thorlabs 635nm Laser Diode

This Thorlabs laser diode operates at a typical wavelength of 635 nm (minimum 630 nm, maximum 645 nm) with an average output power of 4.5 mW +/- 0.5 mW. The laser diode has an operating voltage between 4.9 V to 5.2 V and an operating current between 50 mA and 70 mA. The FWHM of the laser is approximately less than 1 nm. Dr. Han has advised that this laser will be sufficient for generating Raman scatter. One concern, however, is the fluorescence from the sample at this wavelength. Fluorescence can be mitigated by pre-exposing the sample to the beam in order to photobleach it prior to taking the measurement.

7.3.2 Optical Fibers

Optical fibers can propagate light information from the laser source to the probe and from the probe to the spectrometer. The fibers used in the system must have high throughput and a large signal-to-noise ratio. As light propagates through a fiber, the fiber generates a background signal that can reduce the SNR making Raman analysis difficult. The use of filters in the probe, as described in the section on the probe design, will filter the background noise generated by the fiber as well as block the Rayleigh scattering. The optical fibers chosen must maximize the collection efficiency of the signal from the sample. [29] A great advantage of using fibers is the elimination of the need for alignment. When optical fibers are manufactured, they are doped with OH⁻ ions due to the plasma torches used to soften the silica to be drawn. Fibers with a high OH⁻ concentration exhibit water absorption peaks in the NIR. Therefore for our application, low OH⁻ fibers should be chosen to mitigate water absorption peaks. To couple light into the fibers requires lenses with certain focal lengths. Knowing the mode field diameter (ρ) of the fiber, the focal length of the lens is calculated as $f = D^2 / (4\rho)$, where D is the laser beam diameter and ρ is the excitation wavelength.

7.3.3 Diffraction Gratings

Diffraction gratings can be transmissive or reflective, allowing for variations in the setup of the spectrometer. Reflective gratings consist of ruled and holographic gratings. Ruled gratings have physical grooves etched onto the substrate. Holographic gratings have a sinusoidal variation in refractive index of the substrate. Each grating has its benefits. Ruled gratings are less expensive but may result in more stray light due to groove imperfections. Holographic gratings can correct for stray light, improving the efficiency of the spectrometer, but are more expensive. However, holographic gratings can also be designed directly onto a concave focusing mirror to both disperse and focus the light onto a detector. Because Raman spectroscopy requires a high signal-to-noise ratio, a holographic grating may be the more suitable option. Transmissive gratings, on the other hand, can make alignment simpler and are insensitive to the polarization of the incident light. An important specification in choosing the correct grating will be based on the diffraction efficiency at the specified wavelength, or blaze wavelength.

Following are some equations for determining the dispersion, spectral range, and groove density of the grating. The angular dispersion of the grating can be calculated as $d\theta/d\lambda = m / (d \cos \theta)$. Here is the diffraction angle of the light from the grating, m is the diffraction order, and d is the groove period, which is the reciprocal of the groove density. The linear dispersion, assuming a small angle approximation, can be calculated as $dL/d\lambda = 10^6 d \cos(\theta) m / F$, where L is the length of the grating and

f is the focal length of the focusing mirror or lens. The maximum spectral range covered by the detector will be $(\lambda_{\max} - \lambda_{\min}) = L \cdot d / \lambda_{\min}^2$. The detector length L is the product of the total number of pixels on the detector with the pixel width. The minimum resolvable wavelength difference by the grating is $\Delta\lambda = \lambda^2 / N \cdot d$ with $L_g = 1 \text{ m}$, N with L_g as the length of the grating and N as the total number of grooves on the grating. The upper limit on the spectral range, or longest wavelength diffracted by the grating, is twice the groove period.

7.3.4 Wavelength Filters

Optical filters will be required as part of the probe and spectrometer designs. **Figure #** below demonstrates the functionality of the filters. Basic filter types include bandpass, short-pass, long-pass, and notch. The bandpass filter, also known as the laser line filter, allows the transmission of a narrow range of wavelengths. A bandpass filter may be used in the probe to clean up the laser line of the excitation light if the spectral width of the light is more than a few nanometers. Short-pass and long-pass filters are types of edge-pass filters. The short-pass filter allows the transmission of wavelengths smaller than the desired cut-off wavelength. The long-pass filter allows the transmission of wavelengths greater than the desired cut-on wavelength. These filters are used to isolate portions of a spectrum. A long-pass and/or short-pass filter may be used within the probe to block the Rayleigh scattered signal, allowing only the transmission of Stokes and/or Anti-Stokes Raman scattering, respectively. Notch filters block the transmission of the laser line, allowing the transmission of the Stokes and Anti-Stokes Raman scattering. A short-pass filter and long-pass filter can be combined to act as a notch filter.

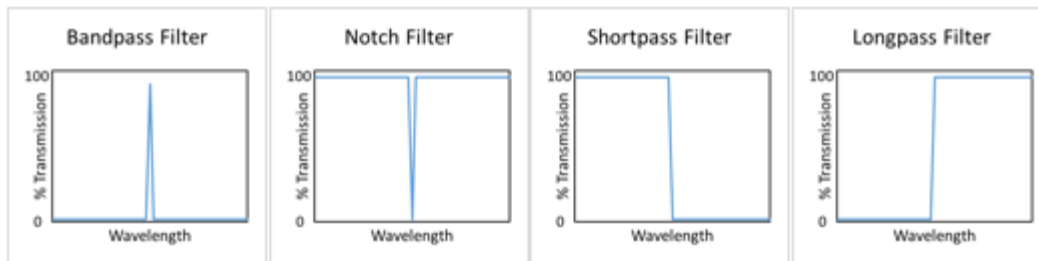

Figure 13: Different Types of Optical Filters and Wavelengths Transmitted

Another type of optical filter is the fiber Bragg grating (FBG). These gratings are etched directly into the optical fiber. The grating is a variation in refractive index, acting as a wavelength selector. The FBG can be used to reflect certain wavelengths. Some advantages of this built-in grating are its narrow bandwidth, low optical loss, and low production cost.

7.3.5 Lenses and Mirrors

The Raman spectrometer and probe will require the use of lenses and/or mirrors. Lenses within the probe will be used for focusing, collimation, and coupling into the optical fibers. A lens or mirror within the spectrometer will collimate the light from the slit onto the diffraction grating. Light from the grating will then be focused by a lens or mirror onto the detector array. There are concave mirrors available with dielectric coatings for NIR and visible wavelengths. Plano-convex lenses can collimate light from a point source or converge collimated light.

7.3.6 Optics Handling

On a technical, optical elements such as mirrors, lenses, gratings, and optical fiber are sensitive and may be damaged easily. Manipulation of the optics must be gentle. It is imperative to handle the optics in a way as to not add fingerprints, oils, scratches, or other imperfections because the performance of the optics will be negatively affected. Additionally, keeping the optics clean prevents scattering and damage upon incident laser light.

There are best practices when handling and cleaning optics. Gloves or finger cots should be worn to prevent damage. If an optic is dusty, the best first step is to clean it with a canned air duster. Wiping a dusty optic may scratch it. A solvent such as acetone or methanol can be used in combination with a lens tissue to wipe an optic. Lens tissues used to clean the optics should never be reused as leftover dust and dirt may damage the optics. In order to keep optics safe, they should be wrapped in lens tissue and stored in an appropriate container when not in use.

7.4 Casing Design

The purpose of the plastic casing is to safely house the Raman spectrometer and all individual parts to protect the electronic parts. Another important purpose for the casing is that it will protect the user from the laser and make the device more comfortable to use. The cables to deliver power and provide data connectivity will also run through the casing. Thus, the design of the overall casing will be efficient from the perspective of the engineering team while ergonomic for the device user.

First, the parts made out of filament for use in the 3D printer must be considered. These pieces include:

1. Housing apparatus for laser/probe
2. Housing for PCBs, microcontrollers, and CCD sensor

The housing apparatus for the laser must be able to securely hold the laser in place, be easy to hold, be cool to the touch, and be protected with lead foil. It must also securely hold buttons to control power and PCB functionality. This piece will contain the probe apparatus and most of the optical pieces. Thus, the dimensions of the laser, heat sink, and optical pieces will determine the dimensions of this portion of the casing; the goal being to have as minimal a size as possible in order to be user friendly.

Element Name	Element Dimensions(l*w*h)(mm)
Raman Probe	(Pending)
Spectrometer	(Pending)
Microcontroller	
PCB	
CCD Array	42.1*10.66*9.72

Table 3: Device Element Dimensions

From the table above, it is noted that the housing for the laser and associated parts must have dimensions of at least SIZE DIMENSIONS.

The housing apparatus for the electronic elements must be able to securely hold each element and being cool to the touch. A main focus will be placed on securing and protecting the CCD array to avoid damage to the glass. This major component will be on a PCB connected to the two microcontrollers. Thus, the dimensions of the microcontrollers will determine the dimensions of this portion of the casing. To allow for simple troubleshooting, the CCD array holding place should be secure and protected, while the microcontrollers will be secure but able to be removed easily. Another element placed within this main house is the power control PCB with various electronic elements connected to a cable to plug into a wall outlet as a power source.

7.4.1 Casing Material

The elements of the Raman spectrometer are to be encased in a smooth, relatively slim, and heat safe material. The protective casing will be designed in AutoCAD and created using a 3D printer. As an on market device, the casing would be made of a durable plastic of a higher, more expensive quality. However, due to economic and time constraints, a 3D printer will be used to create the casing for the prototype designed in the L.A.S.E.R.S. system. Various goals must be met for this aspect; the casing is to have an attractive design that is ergonomic and feels smooth and cool to the touch. The heat of not only the general electronic elements but also the laser must be considered. Thus, the chosen plastic must be relatively heat resistant and able to handle the functionality of the device. It is also important that the material is non-conductive or at least minimally conductive for safety. The casing should protect parts of the device and make it more user friendly and approachable.

The main types of plastic for use in 3D printers are Acrylonitrile-Butadiene Styrene (ABS) and PolyLactic Acid (PLA). PLA filament is plant-based and considered to be more environmentally friendly, while ABS is oil based and more difficult to destroy [30]. As the article “PLA vs ABS: Filaments for 3D Printing Explained & Compared” describes, these characteristics define which type of filament is ideal for a certain type of project. As mentioned previously, the glass point or glass temperature is important to meet the temperature constraints of the system. The glass temperature will give the team an idea of what type of filaments is more ideal for this particular application, which will include some heating to a degree. PLA filament has a lower glass point than ABS, and the article states that, “ABS is better suited for objects that need to withstand rough usage, hot environments, that need to be weather-proof, that may be dropped or have to be bendable. It can be used for parts that are subject to mechanical stress, for interlocking parts or pin-joints,” [30]. ABS filament is more durable and able to handle a variety of situations that require regular use. Thus, ABS filament appears to be the ideal material for the casing of the spectrometer.

Options considered are as follows:

Brand	Specific Product	Price	Glass Temperature (degrees Celsius)
SainSmart	1.75mm ABS Filament 1kg/2.2lb for 3D Printers	\$26.99	100-105
Gizmo Dorks	RED ABS 3D Printer Filament, Dimensional Accuracy +/- 0.05 mm, 1 kg Spool, 1.75 mm, Red	\$21.99	100-105
iXCC	White ABS 3D Printer Filament 1.75mm Diameter (Dimensional Accuracy +/- 0.05mm) 1kg Spool	\$19.99	100-105

Table 4: Comparison of Filament

The dimensions and properties of all ABS filament options explored are roughly the same. The colors and brand specific additives vary. With regard to pricing as well as reviews found on Amazon, the SainSmart product appears to be reliable and affordable.

While the team has researched the brands and products above, the matter of 3D printing on a machine or by sending out the casing design is still to be determined. Services exist online where one can send out a CAD design and receive the finished product in the mail. From a service like this, the team would just have to verify that the company or individual printing the casing design has ABS filament, as well as get the product details. The University of Central Florida has a 3D printer in the Manufacturing Lab. The cost of using the Manufacturing Lab's 3D Printer is \$5/cubic inch. The team must create an STL file to of the casing design and request the ability to use the space as well as receive a quote on cost. This step cannot be considered until the casing design itself is complete. Price will be a varying factor that depends on printing location and final design.

In addition to the filament that makes up the majority of the device housing, parts of the casing will be lined with lead foil to protect the user and other device elements from the laser. This foil should be thin, easy to connect and secure to the housing, and relatively inexpensive.

Near infrared radiation ranges from 750 nm to 3000 nm. Inside the spectrometer, it is important to use materials that react to infrared radiation as necessary for our specific application. For example, optical lenses, filters, and windows made of Silicon would exhibit 0% transmission at 785 nm wavelength. Other optical and non-optical properties to consider are index of refraction, coefficient of thermal expansion, thermo-optic coefficient, and hardness. Silicon is commonly used in spectroscopy applications because it is low cost and lightweight.

7.5 Sensor Apparatus

In order to read in the data from the laser, a collector device that fits the needs of the Raman Spectrometer must be chosen. The two main options for the device included either a charge-coupled device (CCD) or complementary metal-oxide-semiconductor (CMOS) array. In general,

a CMOS array is more affordable than a CCD; an attractive choice considering the price point of the optical parts of the system. While a CMOS array is easier to access and often to communicate with, research and consultation with advisors led to the decision to choose a CCD array. Ultimately, the advice of both Dr. David Hagan and Dr. Kyu Young Han solidified this choice that seemed promising from research.

To meet design specifications, the chosen CCD array must be relatively affordable and effective enough to successfully read in the wavelength of the spectra of the testing material. Ideally, the CCD will also have a low power consumption, under 5 V. Based on other Raman Spectrometer projects and suggestions, Toshiba products became a focal point for product research. Toshiba offers linear CCD image detectors from a variety of price points, including sensors with a retail value of under \$50. Options considered are as follows:

Brand	Specific Product	Price Range	Power Consumption
Toshiba	TCD1304AP	\$14.99	4.0 V drive
Toshiba	TCD1305DG	\$34	5.0 V drive
Toshiba	TCD1103GFG(8Z)	\$15.00	3.0 V drive

Table 5: CCD Model Comparison

CCD arrays require high speed analog-digital conversion in order to deliver efficient results. Aside from the above specifications, the chosen CCD must function with a microprocessors such as a RaspberryPi. Simple functionality that does not require many additional configuration steps is ideal, however this is a difficult task for a CCD array. High functioning CCD arrays cannot be directly connected to a RaspberryPi due to port functionality restrictions. This issue can be bypassed by adding in an additional microcontroller, to be discussed in detail within its own section. In short, a Nucleo F401RE will bridge the communication between the RaspberryPi and the CCD array.

With the ability to work with this selection of CCD arrays thanks to workarounds via microprocessors or specific chips, the CCD of choice is the Toshiba TCD1304AP. This specific part has 3648 pixels of size $8\mu\text{m}\times 200\mu\text{m}$, which will be efficient for the wavelength of the laser and the spectrum of focus for the spectrometer [21]. The operating temperature ranges from -25°C to 60°C [21]. This temperature range will be within the overall temperature specifications, and therefore will be at an acceptable operating temperature. This element will also be placed in an area away from the laser and thus will be protected better than if they were housed in the same space.

The above considerations were important in moving forward with the TCD1304. To verify that this part could be successful for the application of Raman spectroscopy, the team asked other optics students and read into any other projects using this part. After seeing at least three projects that utilized the same or similar CCD array for the application of Raman spectroscopy, it was decided that the TCD1304 would be effective. The other options were explored, however it seemed that the quantum efficiency of all explored options were the same, if not similar, at the wavelengths of

interest. There was little advantage found in exploring an option that had seen less of the same application of Raman spectroscopy. With a lack of supporting evidence to go with a similar but more expensive option, the decision was made to move forward with the TCD1304AP.

A few care instructions must be considered for the TCD1304AP, especially when handling this part in our device. The glass on top of the array must be cleaned carefully to maintain maximum functionality and avoid damage. This CCD must avoid exposure to infrared lighting to avoid reduced resolution quality. Soldering at temperatures above 350°C must be quick to avoid damage [21]. Thus, it is essential to take care when handling, testing, and implementing the TCD1304AP. The casing design must properly secure the PCB holding the TCD1304AP and protect it from moving or being hit by another part should something slide out of place .

The CCD array will be placed on a separate PCB to better isolate and protect the part in both the construction process and the typical functionality environment. This separate PCB will contain space for the 22 pin TCD1304AP as well as power and data connectivity.

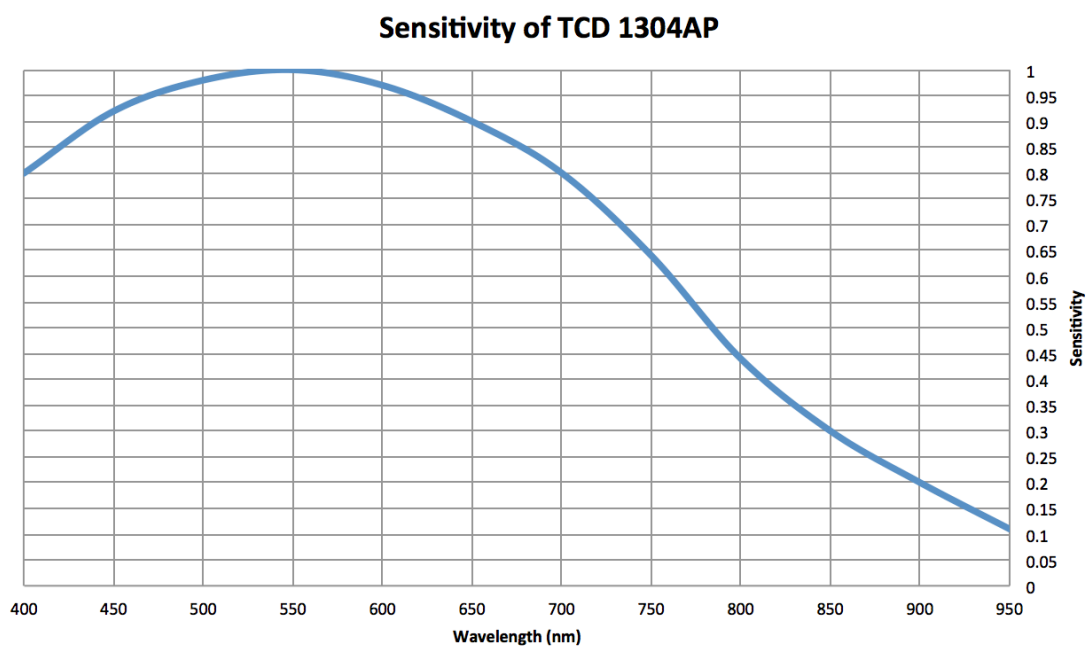

Figure 14: Plot of Sensitivity of TCD 1304AP, information from Data Sheet [21]

An important element of the CCD array is the spectral response. The spectral response or quantum efficiency is the efficiency at which something can detect a certain spectrum of light. Given a wavelength of choice, the datasheet of the specific sensor will show the relative response at that point [21]. From the graph of the spectral response of the CCD, created using information from the TCD1304AP datasheet, one can see the response at the infrared wavelength range used [21]. These data points are taken when the ambient temperature is approximately 25°C. Around the wavelength of 785 nm, the wavelength of focus, the spectral response is around 50%, which is sufficient for this application. Around the wavelength of 635 nm or 632.8 nm, two lasers that may potentially be used in the device, the sensitivity greatly increases to above 90%. Thus, all lasers in question will be able to work with the chosen TCD1304AP CCD array and still meet

specifications, so long as the wavelength is below 825 nm. Given a greater budget, it would be possible to have a higher spectral response; constraints must be considered for this project design.

The TCD1304 data sheet suggests a drive circuit to operate the CCD array. The suggested input voltage is four volts, which is doable for the power control system and could be connected to one of the microcontrollers or directly to the power supply PCB. Should the chosen microcontroller connected to the CCD PCB have a space for a voltage of four volts, or a voltage within the operating range of the CCD, this could simplify the power supply design as well as the overall system.

The two major points of focus to operate the CCD array are power supply and data connectivity. In order to have proper communication with the microcontrollers, the pins dedicated to the signal collected must be understood, as well as the clock, pulse, and frequency information. The voltage input range for both analog and digital input is between 3.0 V and 5.5 V, with 4 V as the optimal input value [21]. When the input voltage is at the optimal value of 4 V, or greater, the data and clock information is as follows:

Characteristic	Symbol	Minimum	Typical	Maximum	Unit
Master Clock Frequency	$f_{\phi M}$	0.8	2.0	4.0	MHz
Data Rate	f_{DATA}	0.2	0.5	1.0	MHz
Master Clock Capacitance	$C_{\phi M}$	N/A	10.0	N/A	pF
ICG Pulse Capacitance	CICG	N/A	250.0	N/A	pF
Shift Pulse Capacitance	CISH	N/A	600.0	N/A	pF

Table 5: Data and Clock Data for TCD1304AP [21]

7.6 Power Flow Design

Power distribution is essential to not only operate the spectrometer, but also to ensure that the laser operates at a most safe state possible, one with the proper amount of power. The main source of power will be a typical US wall outlet that delivers 120 V at a frequency of 60 Hz. Power must run to the following major components: the PCB that will manage the power distribution, the microcontroller system, the CCD sensor, and the heat sink and laser. As per the respective sections for each element, these components require the following power supplies:

Part Name	Minimum Power Required	Maximum Power
Laser	(Pending Specs)	(Pending Specs)
CCD (TCD1304AP)	3.0 V/45 W	5.5 V/82.5 W (if 15 amps)
Arduino	(Pending Specs)	(Pending Specs)
RaspberryPi	5V/10W	6V/12W

Table 6: Power supply required of the components.

Laser

The laser, under a predetermined spectra, will be used to scan the skin for any skin abnormalities/cancerous cells. The laser will obtain the power from the printed circuit board via a copper insulated wire stemming from the interlaced power coming from the wall plug-in. The power to the laser is arguably the most essential, considering that it is the foundation to providing an accurate reading; the power must be kept within the range of specified in the table above. The other insulated wire inside the laser will be primarily for data that will be attached to the charged coupling device for further data determination.

Charged Coupled Device

Once the laser has scanned the sample completely, the charged-coupled device (CCD) will begin to vet through the light sensitive elements by digitally mapping the photo responses into data. This is done using the lead insulated wire running from the handheld laser onto CCD, which is located on the board. For the device to have proper functionality, the power will have to be a minimum of 45 watts and a maximum of 82 watts. Ideally, the CCD drive circuit will take in four volts or 60 watts. While the design has considered that the CCD array will be connected directly to the power control PCB, there are other options that may help simplify the design while keeping the size of the device to a minimum. It is possible to use one of the microcontrollers as the power source for the CCD array. Microcontrollers in question have ports with 3.3 V and 5.0 V, both voltage input values that are acceptable for input voltages for the chosen CCD array, the TCD1304AP, as well as most similar models of CCD arrays that are useful for an application such as a Raman spectrometer.

Arduino

Directly connected to the charged coupled device (CCD) is the Arduino board that serves as the bridge that connects the sensor results into digital data. The arduino's role is to filter out the data collected from the CCD onto the Raspberry Pi, which will be more friendly to provide an output. The arduino that will be used is still pending, therefore, it's power cannot be computed at this time.

Raspberry Pi

Once the Arduino gathers all the data provided by the scan via the CCD. the raspberry pi will then need to communicate that data from the arduino and into a handheld computer or laptop. To ensure the full functionality of the device, the raspberry pi needs to have no less than 10W and no more than 12W of power. Once the device has compiled the data, it will pass on its data via a USB onto the computer/laptop.

Considering the values above, the total ideal power input will be between (MIN WATT) and (MAX WATT). The power will flow following the pattern seen in the Power Flow diagram figure below.

Overall System Power Flow Diagram

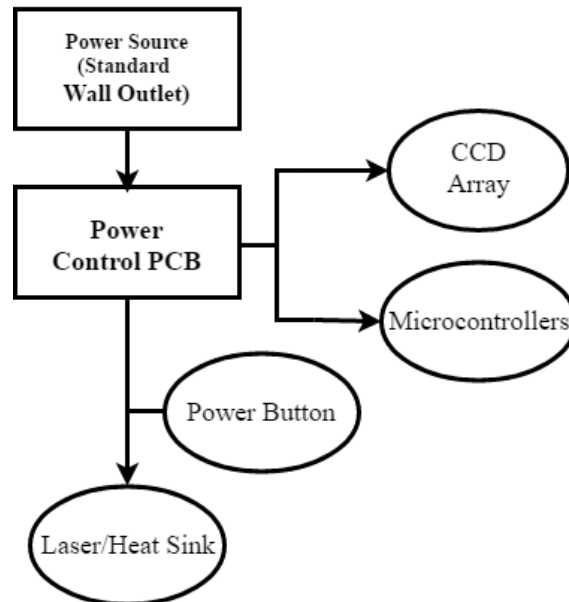

Figure 15: Power Flow Design

In order to distribute this amount from the a typical wall socket, the first element must be the power control PCB. This circuit will take in the electricity from the wall source and into a circuit that regulates the amount of voltage allowed into the spectrometer system. The power control circuit will regulate current and voltage within the system. It will safely distribute power to all major elements of the spectrometer that require the power source.

7.7 Programming Design

The program is the visual representation of our project, and the piece the users will most directly interact with. The combination of the Graphical User interface, Cancer sensing algorithm, and data flow are the pieces responsible for taking a test and displaying them in a way the user can understand. Our design needs to be one that is visually pleasing, user friendly, and most importantly reliable.

7.7.1 Cancer Sensing Algorithm

The algorithm is one of the most vital pieces of project, which should look at all results from data collection, and then should provide the user with a binary result of their likelihood of having possible cancerous cells present in the test area.

Using a combination of our Intensity Shift, Phase shift, and distinct important data points, we intend on finalizing an equation that will have the necessary considerations to accurately predict

cancerous cells in the test site. When the results are above a certain threshold of probability, we will indicate to the user that they should get themselves checked for skin cancer through a binary test by a medical professional.

```

PseudoCode:
Arraylist Operational=Arraylist Master
Operational.IntensityChange(arraylist intensityvalues)
Operational.ShiftChange(arraylist shiftvalues)
for(all intensity values)
    Check for large peak changes
for (all shiftvalues)
    Check for large shifts
if(intensity || shift ==true)
    Return true
Else
    Return false
    
```

7.7.2 Graphical User Interface:

The design philosophy behind the GUI for our project will be ease of use. Our project sets out to be an at-home solution to a very complex problem, at home skin-cancer testing. With the complexity and emotion that may arise in our customer during use, we want our app to be intuitive with very few possibilities for the user to get lost during use.

There is very little need for an extra functionality, as the device should be fully contained, the software is more of a stand-alone piece so that the user can view the results easily. There are plans to add extra functionality, such as the ability to directly upload results to doctors, as well any functionality we decide may further help the customer have a pleasant experience using the product.

GUI Flow:



Figure 16: GUI Flow

Screen A: This page is designed to allow the user to have several options on how to begin the test. Currently, the two buttons only either begin the test for those users who are familiar with the procedure, or to view the instructions.

In the future, I would like to add a settings function from this page, to allow the user the make any configuration changes.

Screen B: The instruction page will present a user who is unfamiliar with the system an easy way to understand how to manipulate the device. Though the goal of the design of the overall project was for ease of use, some customers will surely review instructions before use.

In the future, we would like to add a series of quick video instructions for each step, allowing the user to see how the developers perform each step.

Screen C: The testing page should provide the user with a quick glance at what step the program is currently on. Our design will be set to leave out specifics, but it will update the user that steps are being completed in case the program does pause during runtime.

Screen D: The Quick results page is the page in which the program will deliver the basic “Yes” or “No” message, further providing the user with the possibility of viewing the results in a more detailed manner.

In the future, the program will allow the user to remove the quick diagnosis step completely, and simply view the future results.

Screen E: The detailed results page will provide the user with a line graph representation of the data the test has collected. This information will be exportable to several formats, so that the user can use the data in a variety of third-party programs.

7.7.3 Data Flow Design: TCD1304AP

Due to the multiple stage design of our project, the data will flow between several components before the results are output to the user. Tracing the flow of data will be important for troubleshooting any issues we experience while testing, as the runs of cable are possibilities for points of failure.

CCD to Raspberry Pi

The TCD1304AP CCD will be connected to the Raspberry Pi using the following camera pins on the GPIO pin bank.

Pin Number	Name	Purpose	CCD Connection
1	Ground	Ground for CCD	Ground
2	CAM1_DN0	Data Lane 0	
3	CAM1_DP0	Data Lane 0	
5	CAM1_DN1	Data Lane 1	
6	CAM1_DP1	Data Lane 1	
8	CAM1_CN	MIPI Clock	
9	CAM1_CP	MIPI Clock	
13	SCL0	PC Bus	
14	SDA0	PC Bus	
15	+3.3V	Power Supply	

Table 7: Camera Pin Connectivity

The Raspberry Pi will be receiving a data stream from the CCD with information that it will be populating to a two dimensional array list with corresponding values of wavenumber and intensity respectively. The arraylist will store the data for both the operation and documentation feature. To ensure the data set is not corrupted during these processes, independent copies will be made for each function, so that neither can affect the original dataset directly. Providing read-only access to these datasets will be important so that we can ensure the data is not lost, so the test does not have to be repeated by the user. Therefore, when the program is completed, the data can be written to a file so the user can take the data as they please, whether to send to a medical professional, or for repository in another location.

7.7.4 Data Exporting/Storage Design

Due to the nature of our testing, sharing old and current data, as well as viewing old data is vital for a user to be able to track their progress. Our program will allow users to not only save the past results to a file for viewing later, but we also intend for them to be able to export the data into another program altogether. Since the data will be in plain integer values, these data types can be transferred to a number of commonly used data-types such as Excel Files (.xlsx) and Comma-Separated values (.CSV). These file types will allow the user to share their results with others without the need for specialized software, which will allow the user to share the results with medical professionals as necessary.

All data will be stored in a database on the storage of the Raspberry Pi microcontroller, and will be easily accessible from inside our program. This will allow the user to pull up old data results, if they would like to be able to compare old results to new results. The database will be

implemented as a basic folder with file name structure providing format, so the user can easily select the previous test as desired.

7.8 Thermal Flow Design

Since maintaining standard operating temperatures is vital for the reliability in both the short and long term of our project, the thermal flow is a design that is vital to our success. We intend to keep all devices in our system well within their standard operating temperature, at the possibly cost of increased weight, size, and noise. We intend to achieve this using both passive and active cooling solutions, located in strategic positions as to most efficiently cool all components of the spectrometer.

Device Name	Standard Operating Temperature Range
Laser	-10 to 50 °C
Raspberry Pi	
Arduino	
CCD	-25 to 60 °C
PCB	-30 to 60 °C

Table 8: Thermal Operating Ranges

7.8.1 Device Main Body Thermal Design:

The main body is the computational center of our project, and will also be the piece requiring the most cooling. In this situation, we will be implementing both active and passive cooling solutions, which are respectively, a temperature sensor controlled fan, and heat sinks attached to all devices.

Heat Sinks

The heat sinks will be attached to both the laser, and the Raspberry Pi as shown below. These heat sinks will pull the heat off of these temperature sensitive devices, and allow the fan to cool them more efficiently. We have selected a typical staggered fin design with two axes of ridges, which should be easily cut from a solid piece of Aluminum, which will optimize weight, thermal conductivity, and cost in a very effective package.

The heat sinks will be attached to the devices with thermal compound as necessary, which will allow for increased thermal conduction between the devices and the heat sink. From there, the heat sink will have to be held down with a retaining clip, which will be attached to mounting spaces in the device main body.

Fan

The size of our fan will be determined by the final size of the laser and microcontroller systems, but we are currently planning on running one fan with a size of between 80-120mm. The fan we

select will be optimized for static pressure which will allow for the fan to be able to move the air through the heatsink as desired. Current plans will be around a Corsair SP120 which will be controlled through voltage modulation based on temperature readings.

The temperature readings will be taken from a temperature probe attached to both the laser housing, and the Raspberry Pi. These readings will be interpreted in a stand-alone program that will monitor the temperatures of these components several times a second, and then use voltage modulation to increase and decrease the fan speed as necessary.

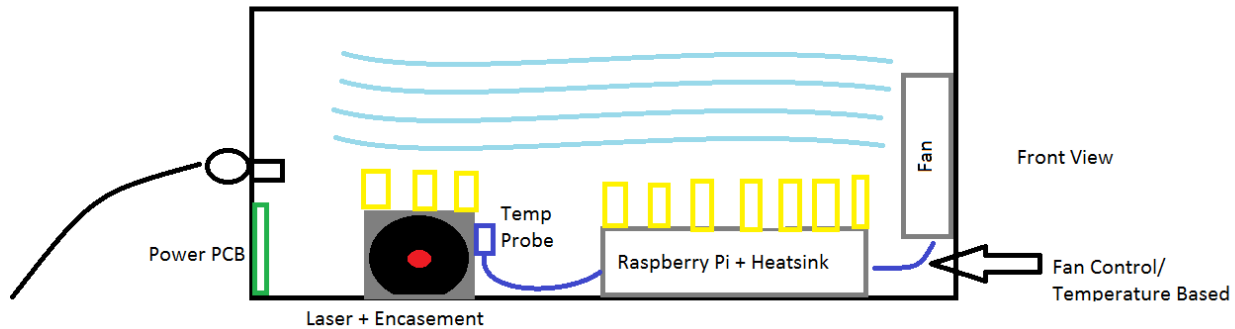

Figure 17: Thermal View of Device Main Body

8 Prototype Construction

Status Pending. This space will discuss the construction of individual modules of the device, such as the probe, as well as how every piece will interconnect. All power and data connections will be made, and the casing pieces will be carefully put together to surround the device components. Great care will especially be taken when working with the optics components and the CCD array's glass top.

9 Project Prototype Testing Plan

In order to be sure that the L.A.S.E.R.S. system is completely functional, first the team must check that each of the major components work properly. Once each component is confirmed to be operating properly, then the device as a whole will be checked. Testing this device for the application of checking for skin cancer in a patient is a challenge, as many guidelines must be followed to ensure patient safety and security. The process of finding a testing material or human subject is in detail below.

9.1 Project Technical Testing

It must be verified that each individual part meets its own design specifications, related standards, and constraints. If the individual components does not function properly, or as expected during the design process, then it must be either replaced or reevaluated for the requirements of the project. The testing process will take place in two phases. The first will take place during Senior Design 1 as parts are selected and verified. During Senior Design 2,

alongside the building process, part will be tested within their respective module of the overall device. The final deliverable will also be fine tuned as the behavior of the final design is learned through the testing process.

9.1.1 Optics Testing

The optical components must be tested independently and assembled. This section briefly describes how to test the functionalities of these components. The components discussed are the laser, fibers, filters, diffraction grating, and lenses and mirrors.

The laser must be powered on. The output power of the laser can be measured using a laser power meter. The characteristic wavelength and bandwidth can be verified using a spectrometer. The laser light must be successfully coupled into the excitation fiber. A power meter at the exit of the fiber can verify that the majority of the optical power propagates through the fiber with minimal loss. A spectrometer at this end can measure the spectra of the light through the fiber to see the extent of fiber background noise.

The excitation light must be filtered, as by a bandpass filter, to narrow the laser line. To test the filter, the laser light can be transmitted through the filter, and a spectrometer on the opposite side can measure the spectral output as compared to the spectral output of the laser itself. The filter can also be tested in a similar manner except with the laser light propagating through the fiber before being transmitted through the filter.

Via the probe, the light must be focused by a lens onto the sample at an appropriate working distance. The reflected light must be collected by this same lens. The collected light must be filtered to block the laser line (Rayleigh signal). A notch or longpass filter may be used for this purpose. This filter can be tested in the same way as the bandpass filter.

The collected light entering the spectrometer through the slit will be divergent. A collimating lens or mirror will collimate this light onto the diffraction grating. Collimation can be verified visually by simply traversing a white paper after the collimation optic to ensure that the beam spot does not grow or shrink in size. Collimation of the dispersion from the grating can be checked in the same fashion.

9.2 Laser Safety Testing

The overall reliability of our spectrometer depends on us being able to accurately scan the skin of our patient, and be able to accurately classify the skin as cancerous or noncancerous. To be able to accurately test our system, samples for calibration and testing of the spectrometer setup will need to be acquired. As part of our proof-of-concept testing phase of the project, we will also need to acquire known cancerous and noncancerous skin samples. A second sponsor, even in a non-financial sense, will need to be a dermatology/skin cancer research center. Possible sponsors include the UCF Health Research facility at Lake Nona, or a large cancer research center such as the Moffitt Center in Tampa. Once a sponsor is confirmed, we can then provide a gauge as to how many samples are needed, their cost, and a solution to create a more time effective scan.

As an alternative to actually testing known cancerous skin samples, it is possible to create simulated results using reflective films that can simulate the cancerous and noncancerous skin samples we intend to receive. This will help remove some of the hurdles that are present in testing on human skin samples, and allow us to be able to test accurately without possibility of corrupting or ruining our acquired skin samples. This would provide the significant improvement to the time constraint for this project. Testing on human skin requires training, for the whole team, which could significantly hinder the time needed to rebuild and design the L.A.S.E.R.S. system. Any ways to streamline the testing process and allow the team to focus on the technical product are ideal.

9.2.1 Analog Replacements for Skin

Due to the inherent difficulties of performing human dermal testing, finding an analog that is the most equivalent to human skin is vital. To try and find an analog that would give us results similar to what we may experience while actually using the spectrometer on human skin. To determine which analog may be the best, we have looked at the analogs used in other dermatological experiments.

Human Skin Equivalent (Graftskin LSE)

Graftskin LSE is a product produced by Organogenesis and is generally used for skin graft procedures in high risk patients. In these patients, removing the amount of skin necessary to cover the wound may do more harm to the patient, and instead Graftskin is used.

Graftskin is a living-cell based product and would allow us to directly test the results of our laser system on fake skin that uses living cells. However, at this time we cannot source a cost for these samples, and since the cost would not be the insurance reduced price patients receive it at, we are confident that this solution would be unnecessary for our project at this time.

Human Reconstructed Epidermis: (Skinethic HRE)

Skinethic RHE is an in vitro reconstructed epidermis created by culturing human keratinocytes. This is biologically very similar to actual human skin, and this is a product used to test:

1. Skin irritation/corrosion
2. UV exposure
3. DNA damage
4. Bacterial Adhesion
5. Omics
6. Permeability

This would be an ideal solution for our needs, however this product is a medical research grade material, and to this time we have not found a way to attain a sample of this product for our tests. Skinethic HRE would allow us to test almost all facets of the safety of our product.

Pig Skin:

Pig skin is a commonly used substitute for products intended for future human use. It is commonly used in a variety of situations, from ballistic tests on popular television shows, to use for practice for aspiring tattoo artists. The reason it is a commonly used substitute is due to the ease of procurement, the relative low cost, and the similarity to human skin.

This will allow us to perform basic safety tests of our spectrometer system, including skin irritation, UV exposure, heat transfer, and any other unforeseen results of our system. This is a low cost option that does not require the approval of a review board at the current time.

As mentioned in the research section of this paper, major spectral features of human skin (normal and cancerous) were due to the proteins and lipids collagen, actin, elastin, and triolein. According to a study done by Vardaxis et al., pig skin is the closest animal analog to human skin “for all types of dermatological and surgical wound investigation.” [Vardaxis] For example, some similarities between human and pig skin are the thicknesses (30-140 mfor pig and 50-120 mfor human) and regeneration rate (approximately 30 days for pig and 27 days for human). Interestingly, pig skin also contains collagen and elastin.

9.3 Optical Properties of Skin

Optical properties of tissue, such as the absorption and scattering coefficients, are of interest when designing our Raman system. It is important to understand how the laser light will be absorbed. The laser light will penetrate a short distance into the tissue and increase in temperature. The scattering of this light is important to consider when designing the collection optics, such as the numerical aperture of the collection fibers.

9.4 Note on Sample Acquisition

Samples for calibration and testing of the spectrometer setup will need to be acquired. As part of our proof-of-concept testing phase of the project, we will also need to acquire known cancerous and noncancerous skin samples. A second sponsor, even in a non-financial sense, will need to be a dermatology/skin cancer research center. Possible sponsors include the UCF Health Research facility at Lake Nona, or a large cancer research center such as the Moffitt Center in Tampa. Once a sponsor is confirmed, we can then provide a gauge as to how many samples are needed, their cost, and a solution to create a more time effective scan.

9.5 Sensor Testing

It must be verified that the sensor array, in this case a CCD array, can read in light and variations of light. This testing can be completed using a breadboard, an oscilloscope, various light sources, a controller, and a drive circuit to power the CCD array. Once the required drive and signal components are placed in the correct positions, testing can begin. A probe of the oscilloscope can be connected to the data output pin of the TCD1304AP array. To prove that the CCD array can not only read in light, but also can detect variations in light, one must vary the light around the array. The tester could flash a bright light across the array and make sure that the output on the oscilloscope varies with the light changes. Ideally, the team will test with a wavelength close to that of which the lasers uses, or a value close.

9.6 PCB Testing

Verifying the functionality of the PCB will require a few tests that will happen at different levels of the PCB fabrication. Since the fabrication will be done by a third party company, most of the testing that can be done will derive from the early stages of the PCB designs: on breadboards, circuit simulators and electronic computer aided design software. Using the breadboard and circuit simulators will be the first true test of the circuits viability. After the breadboard testing passes, the next test will come from the ECAD software that will design the PCB using the previously tested configuration. If that schematic also holds, the schematic will be sent to a PCB fabricator to fabricate and assembly the PCB using the gerber files outputted from the ECAD software. The third party fabricator will also check to see if the circuit schematic is indeed viable, and will perform their own set of stress tests during the fabrication processes. When the PCB is finally returned, the last test that will have to be done is to check if all the contact points on the board produce a value close to the theoretical and experimental results from the previous examinations.

10 Administrative Content

The Administrative Content includes a look at the financial planning and schedule for the project, as well as plans for a crucial parts of Senior Design 2, the final demonstration of the device.

10.1 Estimated Project Budget and Financing

The initial estimate for this project was approximately \$915.00. After conducting further research, the new estimate for this project is approximately \$1,465.00, of which the majority of the cost stems from the optical components. This value would cost less than the average price point of three biopsies. The breakdown of this budget is shown in the table below.

Project Budget	
Item Description	Estimated Cost (\$)
Microcontroller	40.00
Computer	200.00
Detector (CCD or CMOS)	60.00
Wire and Encasing	30.00
3D Printing Filament/Printing	175.00
Lead Foil	20.00
Laser	Available for use*
Optics Parts	900.00
PCB	40.00
Total Estimated Cost	1465.00

Table 9: Estimated Project Budget

*The team currently has access to a Helium-Neon laser (632.8 nm wavelength) through Dr. Han, and a laser diode (635 nm wavelength) in possession of Dr. Kathleen Richardson’s research group.

No sponsors are confirmed at this time. The team plans to contact companies that specialize in medical technology, optics supplies, microcontrollers, laser technology, and 3D printing services. Possible technology sponsors include OptiGrate, Ocean Optics, and Raytheon.

Currently the team is meeting with OptiGrate and Ocean Optics to discuss the objectives, outcomes, and deliverables of L.A.S.E.R.S. in hopes of receiving advising, funding, and/or donations. OptiGrate is a company that specializes in the manufacture of volume Bragg gratings. Ocean Optics is a company that specializes in the manufacture of spectrometers. With the most expensive aspect of the system being the optical parts, it is essential to find a corporation or individual willing to assist with funding or donations of these parts to maintain a logical budget for the device prototype.

10.2 Initial Project Milestones

Milestone	Milestone Date
Divide and Conquer V.1	02/03/2017
Overall design finalized	Mid February 2017
Divide and Conquer V.2	02/17/2017
Parts and materials finalized	Mid March 2017
Initial draft of documentation	03/31/2017
Sponsors contacted	March 2017
CAD, optics system, PCB, pseudocode, user interface design	Late March 2017
Vendors Contacted	March-April 2017
Parts ordered	April-May 2017
120 page final document	04/28/2017
Begin building	Late April-May 2017
Conference paper	June 2017
Midterm demo	Late June 2017
Final presentation and demo	Late July 2017

Table 10: Initial Project Milestones

10.3 Preliminary Demonstration Plans

Making sure that this project can be proven a success during the ten minute demonstration is essential. The demo will show that the elements of the system work by proving laser, sensor, and user interface functionality. Then the demonstration will shift to proving that the system as a whole works with a quick test to prove that it can illuminate and measure a sample and accurately analyze the resulting spectra. Any testing for the specific application of cancer detection may be limited to a demo video to be shown.

11 Project Summary and Conclusions

The project described within these pages is a Raman spectrometer with a probe for *in vivo* analysis of skin. The purpose of this project is to develop a working instrument capable of identifying cancerous traits in the spectra of skin. Research was conducted on all aspects of the project from basic theory to design and applications. There are multiple disciplines that needed to be researched and analyzed, from Raman spectroscopy, spectroscopy of human skin and pig skin, to electronic components, PCB configurations, and microcontroller functions. This was necessary to ensure that the project in the end will have a fully functioning spectrometer that can detect and analyze skin cells at a high success rate.

In regards to the actual design of the project, it is imperative that the design (that will be created in the coming months) complies with the standards found on the various components, as well as meet its size, time, power, and safety constraints. The design layout was made specifically to eliminate risk of component fallibility by enlisting a modular system with PCB's dedicated to specific tasks. From the laser, the data from scanning the sample will be collected onto the CCD, which is mounted on a PCB. From there, the CCD sends the data to the microcontrollers to further modulate the information. The microcontrollers will be on another PCB that will be dedicated just to them. The last PCB is primarily used for power control amongst the other PCB's in the system. The hope is that this modular system will alleviate a lot of the difficult troubleshooting tasks that would be present in an inflexible system that comprises all its components under one encasing.

At this stage of the L.A.S.E.R.S. project, the next steps in the next coming weeks will be to finalize component selection and to order the parts. After receiving guidance from Ocean Optics and OptiGrate, the spectrometer and probe design can be optimized considering compactness and total cost. Then all other elements of the system -- electronics and software -- can be combined and tested. The L.A.S.E.R.S. project will be fully constructed and functional by the demonstration deadline in July.

12 References

1. Gniadecka, M., H. C. Wulf, N. Nymark Mortensen, O. Faurskov Nielsen, and D. H. Christensen. "Diagnosis of Basal Cell Carcinoma by Raman Spectroscopy." *Journal of Raman Spectroscopy* 28.23 (1997): 125-29. Web.
2. Schut, Tom C. Bakker, Peter J. Caspers, Gerwin J. Puppels, Annieke Nijssen, Freerk Heule, Martino H.a. Neumann, and Donal P. Hayes. "Discriminating Basal Cell Carcinoma from its Surrounding Tissue by Raman Spectroscopy." *Journal of Investigative Dermatology* 119.1 (2002): 64-69. Web.
3. Silveira, Landulfo, Fabrício Luiz Silveira, Benito Bodanese, Renato Amaro Zângaro, and Marcos Tadeu T. Pacheco. "Discriminating model for diagnosis of basal cell carcinoma and melanoma in vitro based on the Raman spectra of selected biochemicals." *Journal of Biomedical Optics* 17.7 (2012): 077003. Web.
4. Eikje, Natalja Skrebova, Katsuo Aizawa, Takayuki Sota, Yukihiro Ozaki, and Seiji Arase. "Identification and Characterization of Skin Biomolecules for Drug Targeting and Monitoring by Vibrational Spectroscopy." *The Open Medicinal Chemistry Journal* 2.1 (2008): 38-48. Web.
5. Zhao, Jianhua, Harvey Lui, David I. Mclean, and Haishan Zeng. "Real-time raman spectroscopy for non-invasive skin cancer detection - preliminary results." *2008 30th Annual International Conference of the IEEE Engineering in Medicine and Biology Society*(2008): n. pag. Web.
6. Kourkoumelis, Nikolaos, Ioannis Balatsoukas, Violetta Moulia, Aspasia Elka, Georgios Gaitanis, and Ioannis Bassukas. "Advances in the in Vivo Raman Spectroscopy of Malignant Skin Tumors Using Portable Instrumentation." *International Journal of Molecular Sciences* 16.7 (2015): 14554-4570. Web.
7. Hendi, Ali, and Juan Carlos. Martinez. *Atlas of skin cancers: practical guide to diagnosis and treatment*. Heidelberg: Springer, 2011. Springer. Web.
8. Patterson, James W. "An Approach to the Interpretation of Skin Biopsies." *Weedon's Skin Pathology*. 4th ed. N.p.: Elsevier Limited, 2016. 3-18. Web.
9. Lewis, Ian R., and Howell G. M. Edwards. *Handbook of Raman Spectroscopy from the Research Laboratory to the Process Line*. New York: Marcel Dekker, 2001. Print.
10. McGarvey, J. J., and J. Renwick Beattie. "Raman Microscopy: A Versatile Approach to Bio-Imaging." *Raman Imaging: Techniques and Applications*. Vol. 168. N.p.: Springer, 2012. 219-42. Springer Ser. in Optical Sciences. Web.
11. Butler, Holly J., Lorna Ashton, Benjamin Bird, Gianfelice Cinque, Kelly Curtis, Jennifer Dorney, Karen Esmonde-White, Nigel J. Fullwood, Benjamin Gardner, Pierre L. Martin-Hirsch, Michael J. Walsh, Martin R. McAinsh, Nicholas Stone, and Francis L. Martin. "Using Raman Spectroscopy to Characterize Biological Materials." *Nature Protocols* 11.4 (2016): 664-87. *Nature*. 10 Mar. 2016. Web.
12. Dr. Weibo Cai, "Engineering Multivalent and Multispecific Protein Therapeutics." *Engineering in Translational Medicine* 14.3 379. (2014) Book
13. "Sensitivity and Specificity." Sensitivity and Specificity. N.p., n.d. Web. 23 Mar. 2017.
14. Schoonjans, Frank. "ROC curve analysis with MedCalc." *MedCalc. MedCalc Software*, 31 Jan. 2017. Web. 23 Mar. 2017.

15. Krafft, C., Schie, I. W., Meyer, T., Schmitt, M., & Popp, J. (2016). Developments in spontaneous and coherent Raman scattering microscopic imaging for biomedical applications. *Chemical Society Reviews*, 45(7), 1819-1849. doi:10.1039/c5cs00564g
16. G. Köklü, J. Ghaye, R. Beuchat, G. De Micheli, Y. Leblebici and S. Carrara, "Quantitative comparison of commercial CCD and custom-designed CMOS camera for biological applications," *2012 IEEE International Symposium on Circuits and Systems*, Seoul, 2012, pp. 2063-2066. doi: 10.1109/ISCAS.2012.6271688
17. Wodehouse, Carey. "Basics of Printed Circuit Board (PCB) Design." Hiring | Upwork. N.p., 10 Jan. 2017. Web. 28 Mar. 2017.
18. "Printed Circuit Board." How Products Are Made. N.p., n.d. Web. 28 Mar. 2017.
19. "The Basics Of PCB Design: Components & Construction." PCB Train Blog. N.p., 16 Feb. 2017. Web. 28 Mar. 2017.
20. "What is SMT Surface Mount Technology - Tutorial." What is SMT | Surface Mount Technology | Devices SMD | Radio-Electronics.com. N.p., n.d. Web. 29 Mar. 2017.
21. "Where Electronics Begins™." *About the EDA Industry | The Electronic System Design Alliance*. N.p., n.d. Web. 29 Mar. 2017.
22. "PCB Manufacturing Process-How to make PCB,Fabrication,Design,Guidelines." *Electronic Circuits and Diagram-Electronics Projects and Design*. N.p., 21 Nov. 2011. Web. 30 Mar. 2017.
23. Cha, Sung-Hyuk. "Comprehensive Survey on Distance/Similarity Measures between Probability Density Functions." *INTERNATIONAL JOURNAL OF MATHEMATICAL MODELS AND METHODS IN APPLIED SCIENCES* 2007th ser. 1.4 (2007): 300-07. *Users.uom.gr*. Web.
24. *IEEE Recommended Practice-General Principles for Temperature Limits in the Rating of Electrical Equipment and for the Evaluation of Electrical Insulation*, IEEE Standard 1-2000, 2005.
25. *IEEE Standard for Terminology and Test methods for Analog-to-Digital Converters*, IEEE Standard 1241-2010, 2011.
26. Seshasayee, Nikhil. "Understanding Thermal Dissipation and Design of a Heatsink." (n.d.): n. pag. *Www.ti.com/lit/an/slva462/slva462.pdf*. Texas Instruments, May 2011. Web. Mar. 2017.
27. Jul 17, 2013 Nicholaus Smith | Electronic Design. "The Engineer's Guide To High-Quality PCB Design." *Embedded content from Electronic Design*. N.p., n.d. Web. 31 Mar. 2017.
28. Motz, Jason T., Martin Hunter, Luis H. Galindo, Joseph A. Gardecki, John R. Kramer, Ramachandra R. Dasari, and Michael S. Feld. "Optical Fiber Probe for Biomedical Raman Spectroscopy." *Applied Optics* 43.3 (2004): 542. Web.
29. Grieser, Franz. "PLA vs ABS: Filaments for 3D Printing Explained & Compared." *All3DP*. N.p., 14 Jan. 2016. Web. 21 Feb. 2017.
30. Toshiba, "TOSHIBA CCD LINEAR IMAGE SENSOR CCD(Charge Coupled Device)," TCD1304AP datasheet, Oct. 2001.
31. Vardaxis, N. J., T. A. Brans, M. E. Boon, R. W. Kreis, and L. M. Marres. "Confocal laser scanning microscopy of porcine skin: implications for human wound healing studies." *Journal of Anatomy* 190.4 (1997): 601-11. Web.

13 Appendices

1. Email correspondence with the UCF Institutional Review Board.

Found in Sent - knights.ucf.edu Mailbox 

Megan Melvin March 14, 2017 at 5:00 PM 

To: Institutional Review Board [Details](#)

Good evening,

I am a UCF student currently in my senior year. I am part of a senior design team. Our senior design project will be to build and use a spectrometer to measure the spectra of human skin samples and/or the spectra of skin from live human subjects. Our purpose is to use the spectra to determine if the skin is normal or cancerous.

Because we are using skin samples and/or human subjects, I believe our team will need submit an IRB application and undergo the necessary CITI training. Please let me know the steps to be taken by our team members and/or course instructor.

Thank you,
Megan Melvin

Institutional Review Board March 15, 2017 at 8:39 AM 

To: mmelvin [Details](#)

TO: Megan Melvin

Thank you for contacting the IRB. Please visit our website at <http://www.research.ucf.edu/Compliance/IRB/Submissions/index.html>. This site has all the information about getting started, creating an iRIS account, and CITI training, as well as submitting to our iRIS system.

The forms can be found on the following webpage : <http://www.research.ucf.edu/Compliance/IRB/Investigators/forms.html>. Based on your description below, you would need to fill out the HRP-503 - Protocol and HRP-502 either a or b depending on your population.

Please work with your faculty advisor to complete the documents and submit.

If you have any further questions, please let me know.

Regards,

Gillian Morien
IRB Coordinator
Office of Research and Commercialization
University of Central Florida
407-823-2508
Gillian.morien@ucf.edu

[See More](#) from mmelvin



Megan Melvin

March 22, 2017 at 9:35 PM



To: Institutional Review Board

[Details](#)

Hi Gillian,

What forms, if any, will need to be submitted if we only use skin samples/biopsies instead of live human subjects for our study?

Thank you,
Megan Melvin

[See More](#) from Institutional Review Board

Institutional Review Board

March 23, 2017 at 8:07 AM



To: mmelvin

[Details](#)

To: Megan Melvin

You will need to complete the IRB protocol - HRP-503. If you plan to have interaction with human subjects to get the samples, you will need to complete the HRP-502a Adult Consent. If you cannot consent the participants, you will need to justify why in the protocol.

Regards,

Gillian Morien
IRB Coordinator
Office of Research and Commercialization
University of Central Florida
407-823-2508
Gillian.morien@ucf.edu

[See More](#) from mmelvin

Found in Sent - knights.ucf.edu Mailbox



☆ **Megan Melvin**

March 23, 2017 at 10:55 AM



To: Institutional Review Board

[Details](#)

Hi Gillian,

Is there a separate IRB for using samples of dead animals?

Our Senior Design project is already a 120 page paper, so we're trying to figure out our options to tweak our project in order to make things easier on ourselves.

Thank you for your quick responses.

-Megan Melvin

[See More from Institutional Review Board](#)

RE: Senior Design Project Involving Human Subjects

Institutional Review Board

March 23, 2017 at 10:58 AM



To: mmelvin

[Details](#)

To: Megan Melvin

That would be handled by IACUC. Please feel free to email them for more information at iacuc@ucf.edu. We work separately- people and animals.

Regards,

Gillian Morien
IRB Coordinator
Office of Research and Commercialization
University of Central Florida
407-823-2508
Gillian.morien@ucf.edu

[See More from mmelvin](#)

2. Email to B&W Tek requesting permission to use Figure # - Raman probe design
NOTE: Permission was granted. The email correspondence stated that the email was for the confidential use of the recipient, therefore, a picture of the email is not provided here.

First Name *	Last Name *
Megan	Melvin
Email *	Phone *
mmelvin@knights.ucf.edu	3526388127
Company *	
Student	
Type of Product *	Choose a product for Quote
Accessories	BAC101
Country *	
United States	
How did you hear about us *	
Faculty	
Questions/Comments?	
Hello, I am an engineering student at the University of Central Florida. I am writing a paper on Raman spectroscopy and would like to request permission to use Figure 8-5, Typical Design of a Raman Probe from your website (from Spectrometer Knowledge, Part 8: Fiber Optic Probes, http://bwtek.com/spectrometer-part-8-fiber-optic-probes/). Please let me know if I may or may not use your figure in my paper. Thank you.	